

NOTES:
 1. RECOMMENDED SCREW SIZE INTO
 DOOR #6 X 1/2" (PROVIDED BY RAS) QTY 4

CUSTOMER DRAWING

This drawing is the property of Rev-A-Shelf (RAS) and is disclosed in confidence to the extent its subject matter is original to RAS. Any vendor receiving this drawing from RAS shall hold and use this drawing for the sole benefit of RAS and shall not disclose it to, or use or reproduce it for any third party, or perform any act adverse to the interest of RAS with respect to this drawing without the express written permission of RAS. Vendors shall not revise any physical, dimensional or performance characteristic unless authorized by Rev-A-Shelf Engineering.

REV.	DATE	BY	DESCRIPTION OF CHANGE
E	12/7/07	PFC	ECN07-098

INCH [MM]	AMERICAN PROJECTION 	BY	DATE	REV-A-SHELF, INC.	
		HLF	10/19/07	SIZE B	448BC-11 PULLOUT BASE ORGANIZER
TOLERANCES MAT. DEC. (WOOD) .XX ±.03 [.8mm] (OTHER) .XX ±.02 [.5mm] (ALL) .XXX ±.005 [.13 mm] FRACTIONS ±1/32 [.8 mm]		ANGLES ±1/2°	MATERIAL	DRAWING NO. 448-BC-11C	SCALE 0.188
			FINISH	PART NO. 448-BC-11C	SHEET OF 1 2

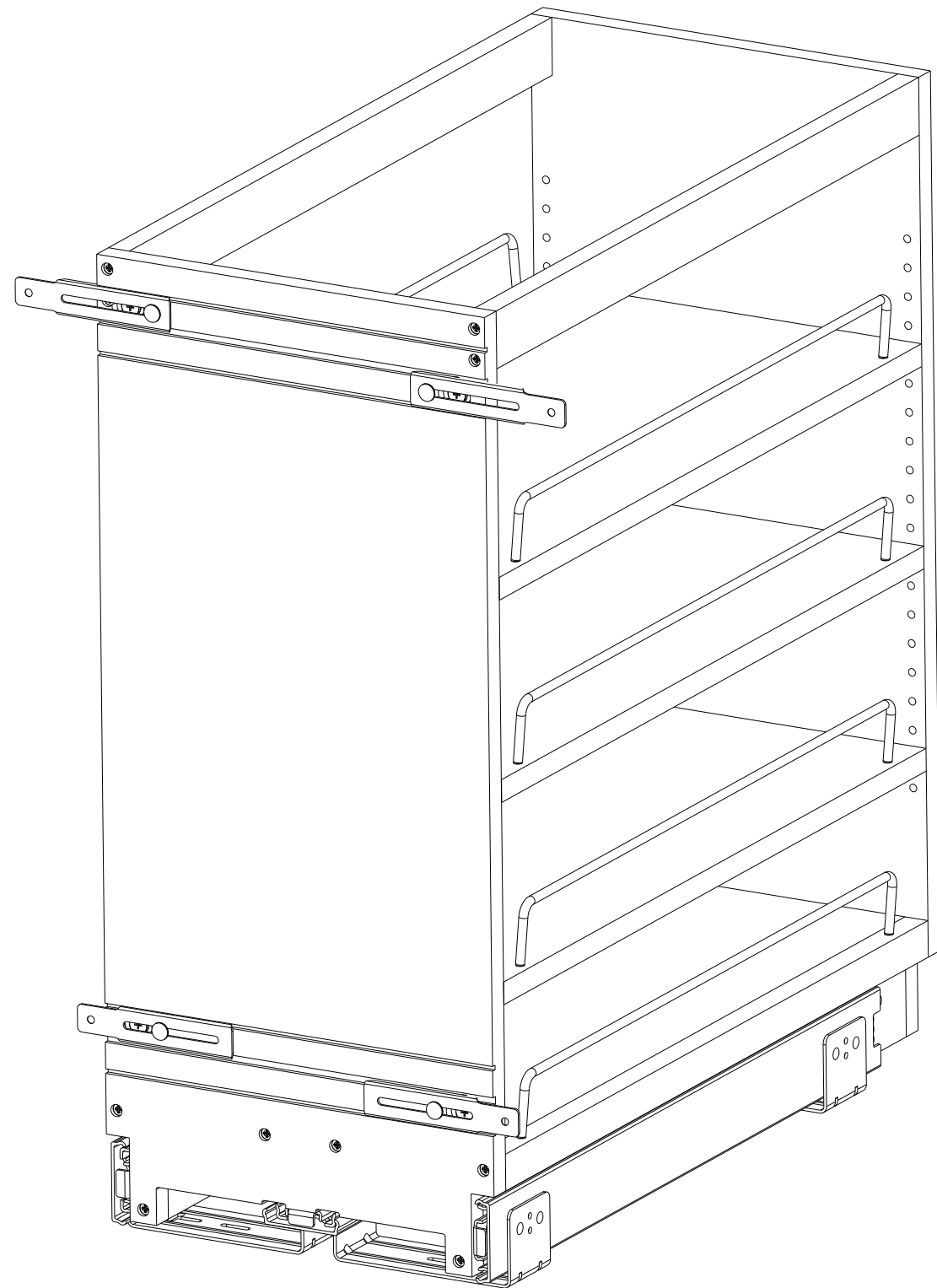

PART DIMENSIONS	
WIDTH	11.00 [279,4]
DEPTH	22.46 [570,5]
HEIGHT	25.47 [647]

MIN CABINET OPENING	
	11.50 [292,1]
	22.50 [571,5]
	25.75 [654,1]

PRODUCT MAX WEIGHT RATING	
BMHA STANDARD	

SLIDE SPECIFICATIONS				
SLIDE TYPE	BALL BEARING	SLIDE EXTENSION	FULL	MAX WEIGHT RATING 150 LB
SLIDE CLOSING	N/A	SLIDE LENGTH	500MM	
SLIDE MOUNTING	N/A	SLIDE FINISH	ZINC	

CUSTOMER DRAWING

This drawing is the property of Rev-A-Shelf (RAS) and is disclosed in confidence to the extent its subject matter is original to RAS. Any vendor receiving this drawing from RAS shall hold and use this drawing for the sole benefit of RAS and shall not disclose it to, or use or reproduce it for any third party, or perform any act adverse to the interest of RAS with respect to this drawing without the express written permission of RAS. Vendors shall not revise any physical, dimensional or performance characteristic unless authorized by Rev-A-Shelf Engineering.

REV.	DATE	BY	DESCRIPTION OF CHANGE
E	12/7/07	PFC	ECN07-098

INCH [MM]	AMERICAN PROJECTION 	DRAWN	BY	DATE	REV-A-SHELF, Inc.
		HLF		10/19/07	
					SIZE B
					DRAWING NO. 448-BC-11C
					SCALE 0.250
					FINISH
					PART NO. 448-BC-11C
					SHEET OF 2 OF 2

TOLERANCES
 MAT. DEC.
 (WOOD) .XX ±.03 [.8mm]
 (OTHER) .XX ±.02 [.5mm]
 (ALL) .XXX ±.005 [.13 mm]
 FRACTIONS ±1/32 [.8 mm]

ANGLES
±1/2°