

CUSTOMER DRAWING

This drawing is the property of Rev-A-Shelf (RAS) and is disclosed in confidence to the extent its subject matter is original to RAS. Any vendor receiving this drawing from RAS shall hold and use this drawing for the sole benefit of RAS and shall not disclose it to, or use or reproduce it for any third party, or perform any act adverse to the interest of RAS with respect to this drawing without the express written permission of RAS. Vendors shall not revise any physical, dimensional or performance characteristic unless authorized by Rev-A-Shelf Engineering.

REV.	DATE	BY	DESCRIPTION OF CHANGE
C	1/28/16	BKT	ECN16-011
B	11/18/15	BKT	ECN15-089
A	5/7/15	BKT	ECN15-030

INCH [MM]	AMERICAN PROJECTION	DRAWN	BY	DATE	REV-A-SHELF, INC.	
			BKT	11/18/17	SIZE	DRAWING NO.
					B	FOOD STORAGE CONTAINER ORGANIZER 18"
			MATERIAL			4FSCO-18SC-1_CUST
			FINISH			4FSCO-18SC-1
						SHEET 1 OF 2

TOLERANCES
 MAT. DEC.
 (WOOD) .XX ±.03 [8mm]
 (OTHER) .XX ±.02 [5mm]
 (ALL) .XXX ±.005 [13 mm]
 FRACTIONS ±1/32 [8 mm]

ANGLES
 ±1/2°

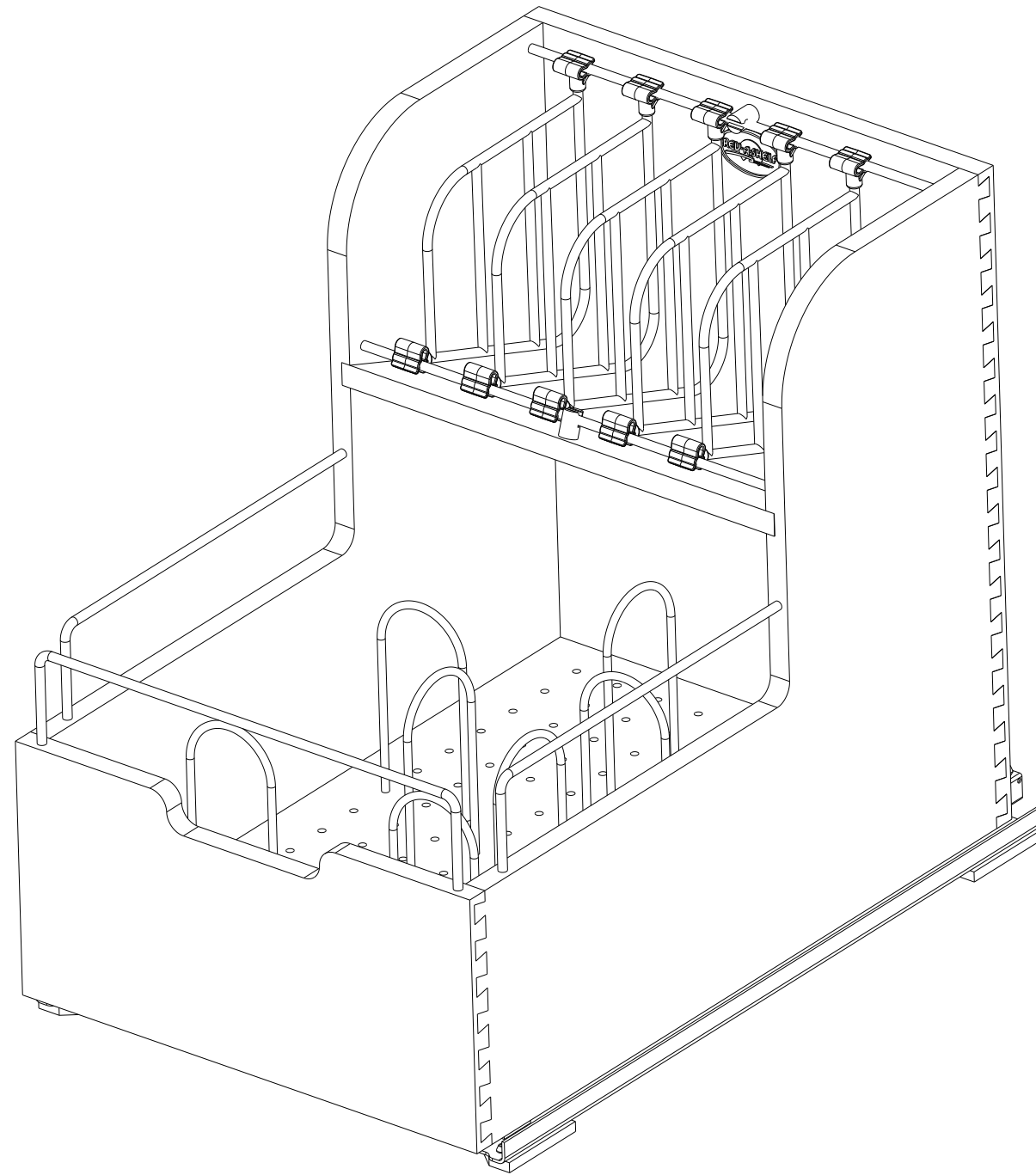

PART DIMENSIONS		
	MIN	MAX
WIDTH	14.50	
DEPTH	22.25	
HEIGHT	18.85	
WEIGHT		
DIAMETER		
RADIUS		
CONTAINER CAPACITY		
CONTAINER UOM		

MIN CABINET OPENING	
WIDTH	15.00
DEPTH	22.38
HEIGHT	19.00

PRODUCT MAX WEIGHT RATING

SLIDE SPECIFICATIONS				
SLIDE TYPE	UNDER MOUNT	SLIDE EXTENSION	3/4" OT	MAX WEIGHT RATING
SLIDE CLOSING	SOFT	SLIDE LENGTH	21 1/2"	
SLIDE MOUNTING	BOTTOM	SLIDE FINISH	ZINC	110 LB

CUSTOMER DRAWING

This drawing is the property of Rev-A-Shelf (RAS) and is disclosed in confidence to the extent its subject matter is original to RAS. Any vendor receiving this drawing from RAS shall hold and use this drawing for the sole benefit of RAS and shall not disclose it to, or use or reproduce it for any third party, or perform any act adverse to the interest of RAS with respect to this drawing without the express written permission of RAS. Vendors shall not revise any physical, dimensional or performance characteristic unless authorized by Rev-A-Shelf Engineering.

REV.	DATE	BY	DESCRIPTION OF CHANGE
C	1/28/16	BKT	ECN16-011
B	11/15/15	BKT	ECN15-089
A	5/7/15	BKT	ECN15-030

INCH [MM]	AMERICAN PROJECTION	DRAWN	BY	DATE	REV-A-SHELF, INC.
			BKT	1/18/17	
					DRAWING NO. 4FSCO-18SC-1_CUST
					PART NO. 4FSCO-18SC-1
					SCALE 0.250
					SHEET 2 OF 2

TOLERANCES
 MAT. DEC.
 (WOOD) .XX ±.03 [.8mm]
 (OTHER) .XX ±.02 [.5mm]
 (ALL) .XXX ±.005 [.13 mm]
 FRACTIONS ±1/32 [.8 mm]

ANGLES
 ±1/2°

MATERIAL
 FINISH