

CUSTOMER DRAWING

This drawing is the property of Rev-A-Shelf (RAS) and is disclosed in confidence to the extent its subject matter is original to RAS. Any vendor receiving this drawing from RAS shall hold and use this drawing for the sole benefit of RAS and shall not disclose it to, or use or reproduce it for any third party, or perform any act adverse to the interest of RAS with respect to this drawing without the express written permission of RAS. Vendors shall not revise any physical, dimensional or performance characteristic unless authorized by Rev-A-Shelf Engineering.

REV.	DATE	BY	DESCRIPTION OF CHANGE

INCH [MM]	AMERICAN PROJECTION 	DRAWN	BY	DATE	REV-A-SHELF, INC.
			KRR	2-19-21	
		MATERIAL		DRAWING NO. 4WCTM-12BBSCDMI	
		FINISH		SCALE 0.188	
				PART NO. 4WCTM-12BBSCDMI	
				SHEET OF 1 2	

TOLERANCES  
 MAT. DEC.  
 (WOOD) .XX ±.03 [.8mm]  
 (OTHER) .XX ±.02 [.5mm]  
 (ALL) .XXX ±.005 [.13 mm]  
 FRACTIONS ±1/32 [.8 mm]

ANGLES  
±1/2°

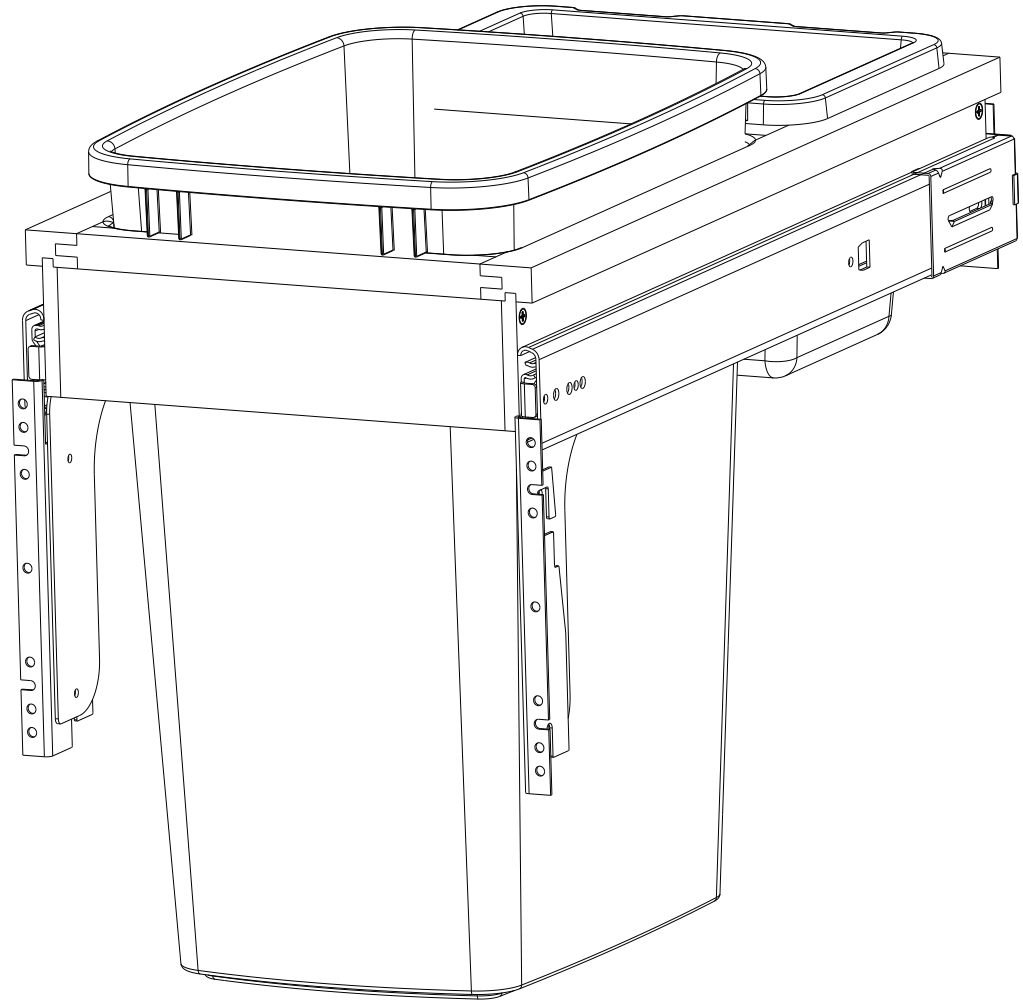

PART DIMENSIONS		
	MIN	MAX
WIDTH	12.00	
DEPTH	22.75	24.00
HEIGHT	17.85	
CONTAINER CAPACITY	35	
CONTAINER UOM	QUART	

MIN CABINET OPENING				
	FACE FRAME	FRAMELESS	INSET FACE FRAME	INSET FRAMELESS
WIDTH	12.00	12.00	12.00	12.00
DEPTH	22.75	22.75	23.50	23.50
HEIGHT	18.35	18.35	18.35	18.35

SLIDE SPECIFICATIONS				
SLIDE MANUFACTURER				
SLIDE PART NUMBER	FX8122	RELEASE PART NUMBER		
SLIDE TYPE	BALL BEARING	SLIDE EXTENSION	1.50" OT	MAX WEIGHT RATING
SLIDE CLOSING	SOFT	SLIDE LENGTH	22.00 [560]	
SLIDE MOUNTING	SIDE	SLIDE FINISH	ZINC	150 LB

CUSTOMER DRAWING

This drawing is the property of Rev-A-Shelf (RAS) and is disclosed in confidence to the extent its subject matter is original to RAS. Any vendor receiving this drawing from RAS shall hold and use this drawing for the sole benefit of RAS and shall not disclose it to, or use or reproduce it for any third party, or perform any act adverse to the interest of RAS with respect to this drawing without the express written permission of RAS. Vendors shall not revise any physical, dimensional or performance characteristic unless authorized by Rev-A-Shelf Engineering.

REV.	DATE	BY	DESCRIPTION OF CHANGE

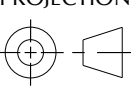
INCH [MM]	AMERICAN PROJECTION 	DRAWN	BY	DATE	REV-A-SHELF, INC. SINGLE 35QT TOP MOUNT SOFT CLOSE
			KRR	2-19-21	
TOLERANCES		ANGLES ±1/2°	MATERIAL	DRAWING NO.	SCALE
MAT.	DEC.		FINISH	4WCTM-12BBSCDM1	4WCTM-12BBSCDM1
(WOOD)	.XX ±.03 [.8mm]				PART NO.
(OTHER)	.XX ±.02 [.5mm]			4WCTM-12BBSCDM1	2 OF 2
(ALL)	.XXX ±.005 [.13 mm]				
FRACTIONS	±1/32 [.8 mm]				