

NOTE: CANS NOT INCLUDED

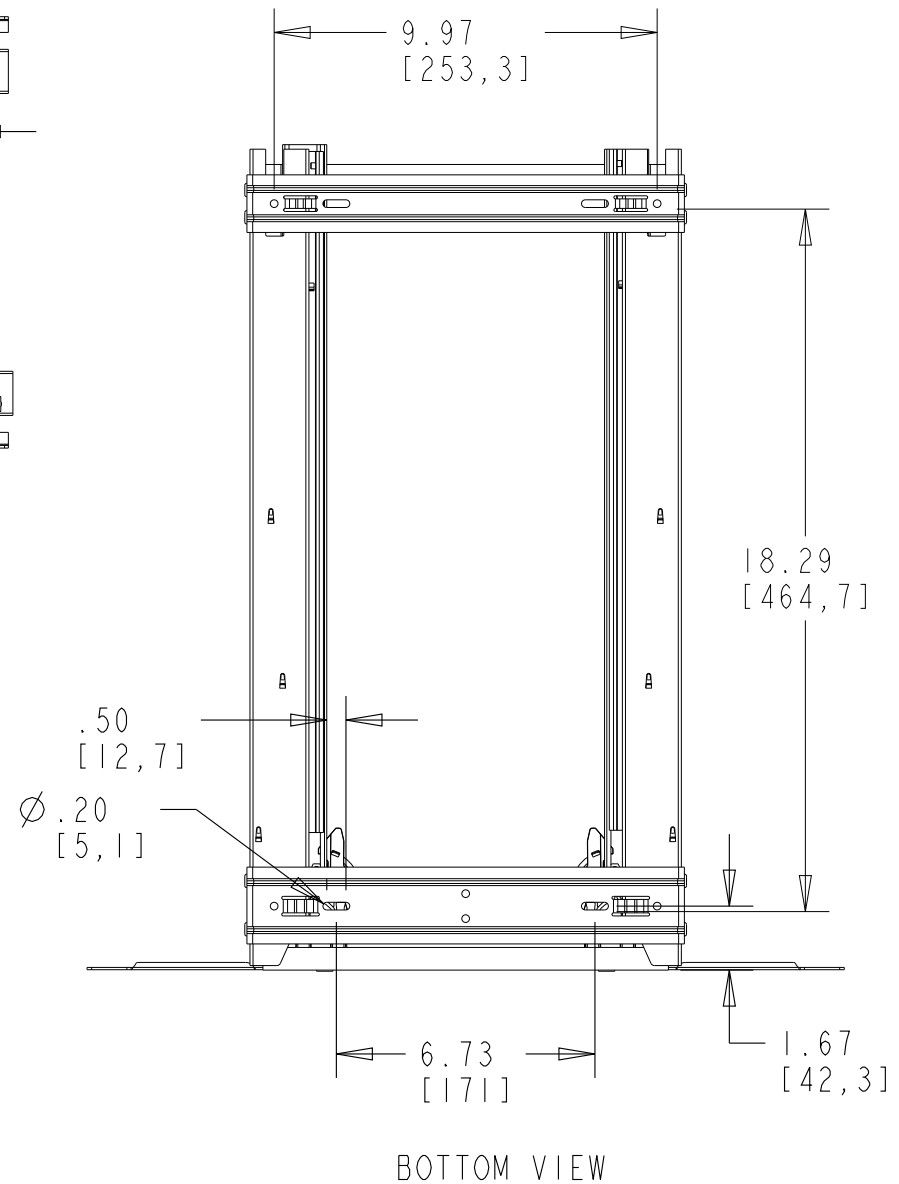
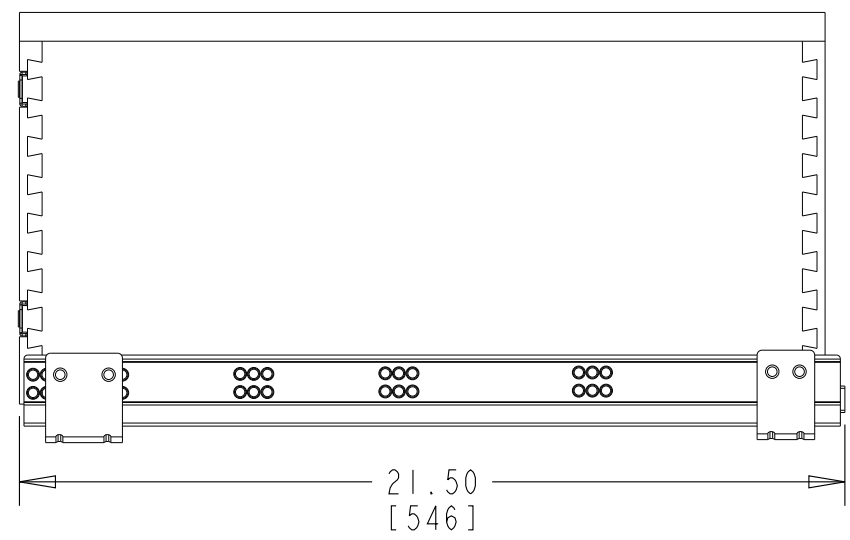
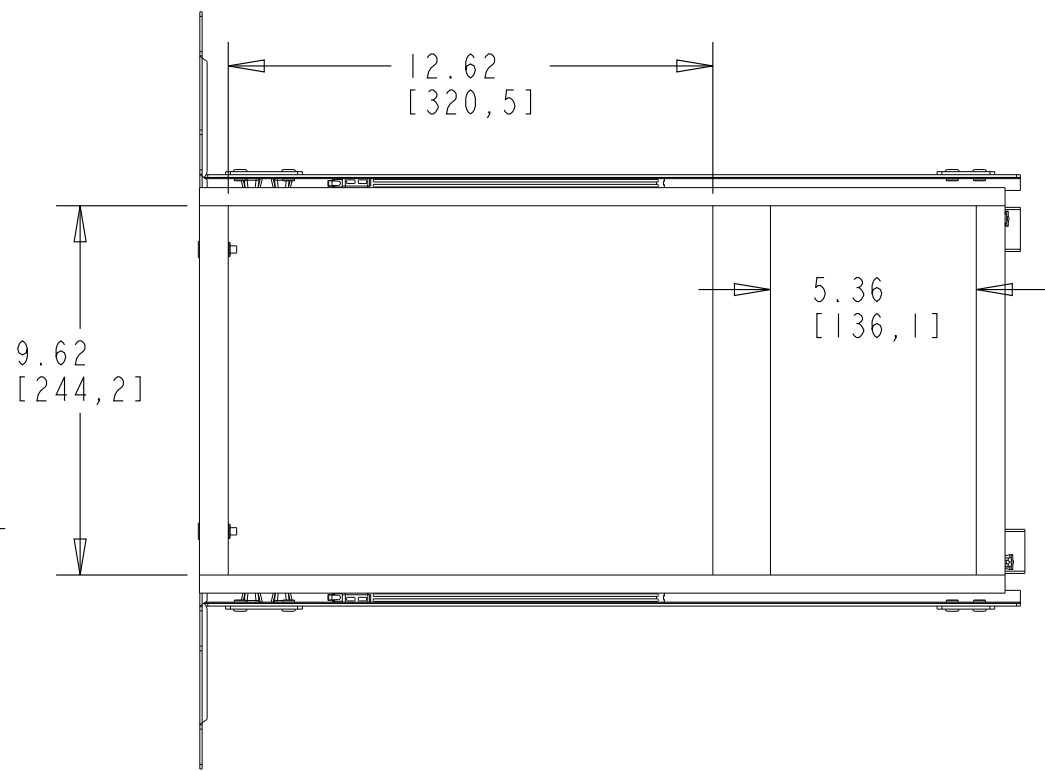
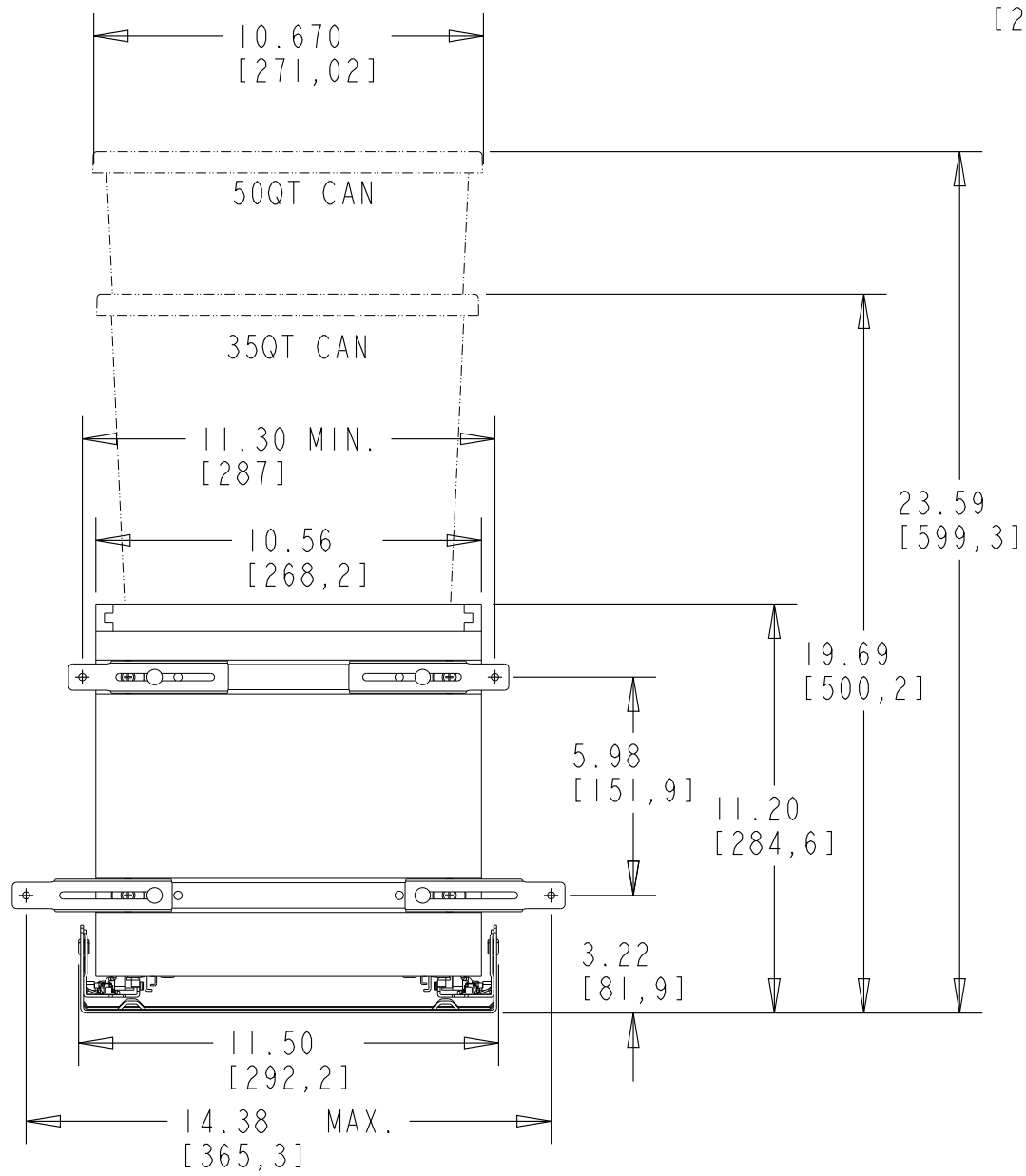

CUSTOMER DRAWING

This drawing is the property of Rev-A-Shelf (RAS) and is disclosed in confidence to the extent its subject matter is original to RAS. Any vendor receiving this drawing from RAS shall hold and use this drawing for the sole benefit of RAS and shall not disclose it to, or use or reproduce it for any third party, or perform any act adverse to the interest of RAS with respect to this drawing without the express written permission of RAS. Vendors shall not revise any physical, dimensional or performance characteristic unless authorized by Rev-A-Shelf Engineering.

REV.	DATE	BY	DESCRIPTION OF CHANGE

INCH [MM]	AMERICAN PROJECTION	BY	DATE	REV-A-SHELF, INC.
		DRAWN	KRR 10-4-21	
TOLERANCES		MATERIAL	DRAWING NO.	SCALE
MAT. DEC. (WOOD) .XX ±.03 [8mm] (OTHER) .XX ±.02 [5mm] (ALL) .XXX ±.005 [13 mm] FRACTIONS ±1/32 [8 mm]		FINISH	4VLWCSC-15XXDM-1	0.200
ANGLES ±1/2°		PART NO.		SHEET OF
		4VLWCSC-15XXDM-1		1 2

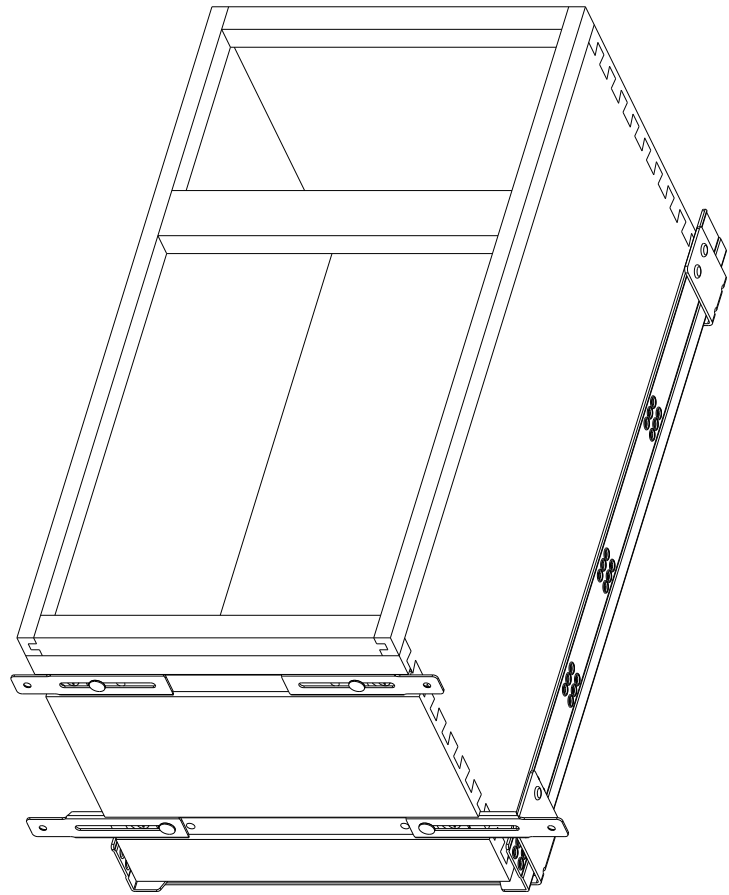

PART DIMENSIONS		
	MIN	MAX
WIDTH	11.50	
DEPTH	21.50	
HEIGHT W/ 35 QT	19.69	
HEIGHT W/ 50 QT	23.59	
CONTAINER CAPACITY	35 OR 50	
CONTAINER UOM	QUART	

MIN CABINET OPENING				
	FACE FRAME	FRAMELESS	INSET FACE FRAME	INSET FRAMELESS
WIDTH	11.50	11.75	11.50	11.75
DEPTH	21.75	21.75	22.50	22.50
HEIGHT W/ 35	20.00	20.00	20.00	20.00
HEIGHT W/ 50	24.00	24.00	24.00	24.00

SLIDE SPECIFICATIONS				
SLIDE MANUFACTURER	BTL			
SLIDE PART NUMBER	BC1A-16-533	RELEASE PART NUMBER		
SLIDE TYPE	UNDERMOUNT	SLIDE EXTENSION	FE	MAX WEIGHT RATING
SLIDE CLOSING	SOFT/SELF	SLIDE LENGTH	21" [533MM]	
SLIDE MOUNTING	BOTTOM	SLIDE FINISH	ZINC	75 LB

CUSTOMER DRAWING

This drawing is the property of Rev-A-Shelf (RAS) and is disclosed in confidence to the extent its subject matter is original to RAS. Any vendor receiving this drawing from RAS shall hold and use this drawing for the sole benefit of RAS and shall not disclose it to, or use or reproduce it for any third party, or perform any act adverse to the interest of RAS with respect to this drawing without the express written permission of RAS. Vendors shall not revise any physical, dimensional or performance characteristic unless authorized by Rev-A-Shelf Engineering.

REV.	DATE	BY	DESCRIPTION OF CHANGE

INCH [MM]	AMERICAN PROJECTION	DRAWN	BY	DATE	REV-A-SHELF, INC.
			KRR	10-4-21	
			MATERIAL	DRAWING NO.	SCALE
			FINISH	4VLWCSC-15XXDM-1	0.200
				PART NO.	SHEET OF
				4VLWCSC-15XXDM-1	2 OF 2

TOLERANCES
 MAT. DEC.
 (WOOD) .XX ±.03 [.8mm]
 (OTHER) .XX ±.02 [.5mm]
 (ALL) .XXX ±.005 [.13 mm]
 FRACTIONS ±1/32 [.8 mm]

ANGLES ±1/2°