

CUSTOMER DRAWING

This drawing is the property of Rev-A-Shelf (RAS) and is disclosed in confidence to the extent its subject matter is original to RAS. Any vendor receiving this drawing from RAS shall hold and use this drawing for the sole benefit of RAS and shall not disclose it to, or use or reproduce it for any third party, or perform any act adverse to the interest of RAS with respect to this drawing without the express written permission of RAS. Vendors shall not revise any physical, dimensional or performance characteristic unless authorized by Rev-A-Shelf Engineering.

REV.	DATE	BY	DESCRIPTION OF CHANGE

INCH [MM]	AMERICAN PROJECTION 	BY	DATE	REV-A-SHELF, INC.	
		DRAWN	KRR	5-13-14	SIZE
TOLERANCES		MATERIAL	DRAWING NO.	SCALE	SHEET OF
MAT.	DEC.				
(WOOD)	.XX ±.03 [8mm]	FINISH	PART NO.	SCALE	SHEET OF
(OTHER)	.XX ±.02 [5mm]				
(ALL)	.XXX ±.005 [13 mm]				
FRACTIONS	±1/32 [8 mm]				

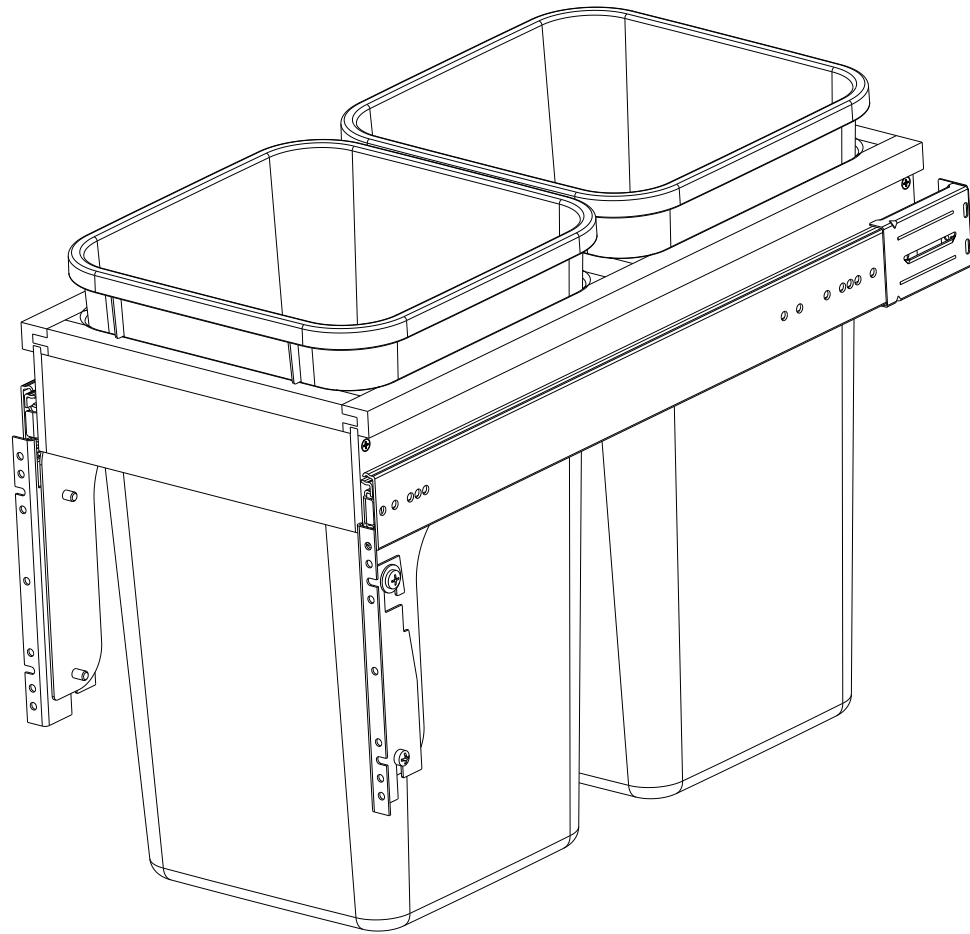

PART DIMENSIONS		
	MIN	MAX
WIDTH	12.00	
DEPTH	23.25	24.50
HEIGHT	17.75	
WEIGHT		
DIAMETER		
RADIUS		
CONTAINER CAPACITY	27 X 2	
CONTAINER UOM	QUART	

MIN CABINET OPENING	
WIDTH	12.00
DEPTH	23.25
HEIGHT	18.25

PRODUCT MAX WEIGHT RATING

SLIDE SPECIFICATIONS				
SLIDE TYPE	BALL BEARING	SLIDE EXTENSION	1-1/2" O.T.	MAX WEIGHT RATING
SLIDE CLOSING	NORMAL	SLIDE LENGTH	22.00 [560,0]	
SLIDE MOUNTING	SIDE	SLIDE FINISH	ZINC	150 LB

CUSTOMER DRAWING

This drawing is the property of Rev-A-Shelf (RAS) and is disclosed in confidence to the extent its subject matter is original to RAS. Any vendor receiving this drawing from RAS shall hold and use this drawing for the sole benefit of RAS and shall not disclose it to, or use or reproduce it for any third party, or perform any act adverse to the interest of RAS with respect to this drawing without the express written permission of RAS. Vendors shall not revise any physical, dimensional or performance characteristic unless authorized by Rev-A-Shelf Engineering.

REV.	DATE	BY	DESCRIPTION OF CHANGE

INCH [MM]	AMERICAN PROJECTION 	DRAWN	BY	DATE	REV-A-SHELF, INC.
			KRR	5-13-14	
TOLERANCES			MATERIAL	DRAWING NO.	SCALE
MAT.	DEC.	ANGLES ±1/2°		4WCTM-15DM2	0.200
(WOOD) .XX ±.03 [.8mm]	(OTHER) .XX ±.02 [.5mm]		FINISH	PART NO.	SHEET OF
(ALL) .XXX ±.005 [.13 mm]	FRACTIONS ±1/32 [.8 mm]			4WCTM-15DM2	2 OF 2