

CUSTOMER DRAWING

This drawing is the property of Rev-A-Shelf (RAS) and is disclosed in confidence to the extent its subject matter is original to RAS. Any vendor receiving this drawing from RAS shall hold and use this drawing for the sole benefit of RAS and shall not disclose it to, or use or reproduce it for any third party, or perform any act adverse to the interest of RAS with respect to this drawing without the express written permission of RAS. Vendors shall not revise any physical, dimensional or performance characteristic unless authorized by Rev-A-Shelf Engineering.

REV.	DATE	BY	DESCRIPTION OF CHANGE
A	1/18/17	BKT	REVISED TO THE MOVENTO

INCH [MM]	AMERICAN PROJECTION 	BY	DATE	REV-A-SHELF, INC.	
		BKT	1/18/17	SIZE B	DOUBLE 30 QUART WASTE CONTAINER BLUM SOFT CLOSE
TOLERANCES		MATERIAL	DRAWING NO.	SCALE	
MAT.	DEC.		4WCSC-24DM2-SC_CUST	0.100	
(WOOD) .XX ±.03 [.8mm]	(OTHER) .XX ±.02 [.5mm]	FINISH	PART NO.	SHEET OF	
(ALL) .XXX ±.005 [.13 mm]	FRACTIONS ±1/32 [.8 mm]		4WCSC-24DM2-SC_CUST	1 2	
ANGLES ±1/2°					

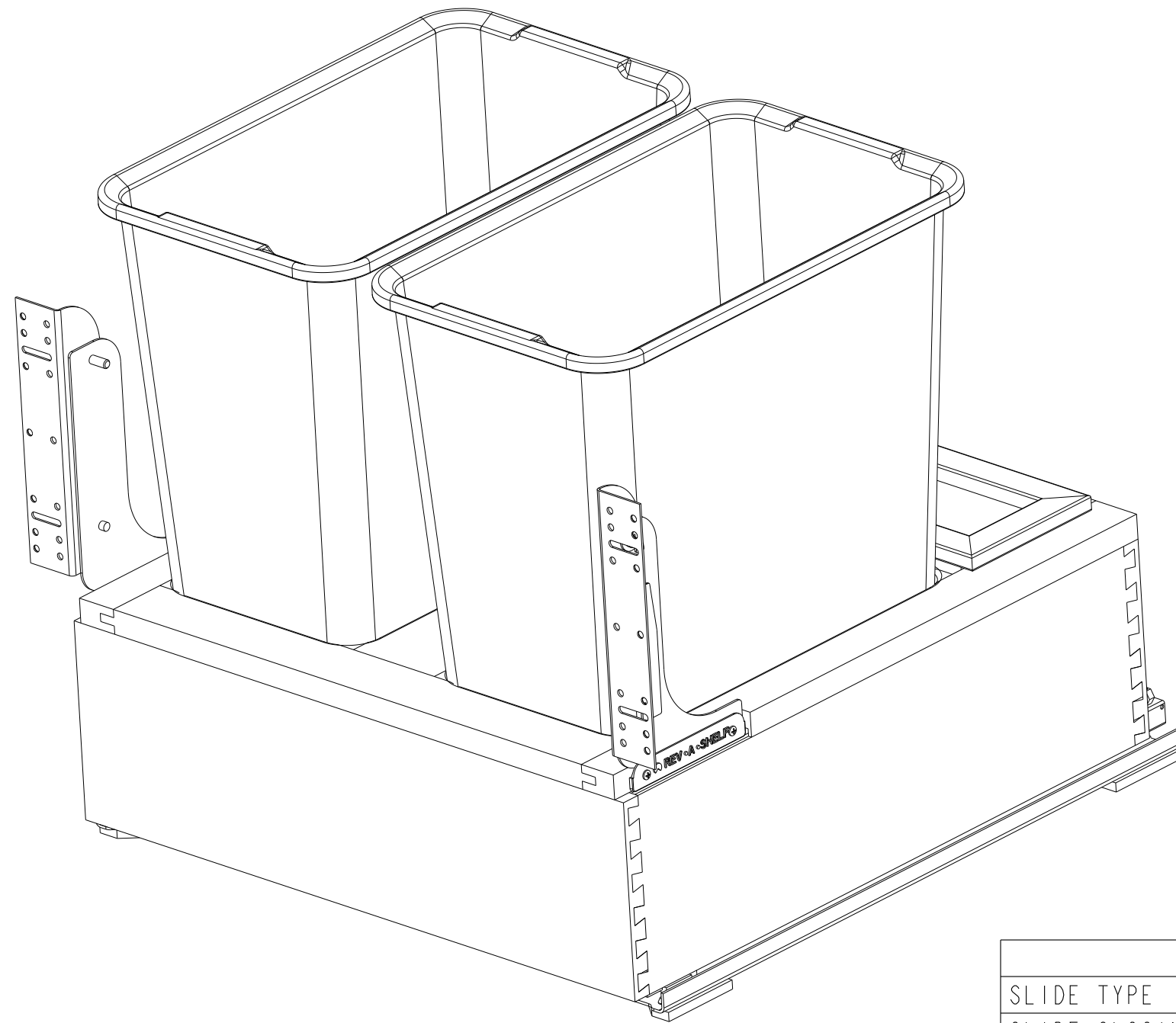

PART DIMENSIONS		
	MIN	MAX
WIDTH	20.97	
DEPTH	22.38	
HEIGHT	19.62	
WEIGHT		
DIAMETER		
RADIUS		
CONTAINER CAPACITY		
CONTAINER UOM		

MIN CABINET OPENING	
WIDTH	21.00
DEPTH	22.38
HEIGHT	19.75

PRODUCT MAX WEIGHT RATING

SLIDE SPECIFICATIONS				
SLIDE TYPE	UNDER MOUNT	SLIDE EXTENSION	3/4" OT	MAX WEIGHT RATING
SLIDE CLOSING	SOFT CLOSE	SLIDE LENGTH	21 1/2"	
SLIDE MOUNTING	BOTTOM	SLIDE FINISH	ZINC	
				110 LB

CUSTOMER DRAWING

This drawing is the property of Rev-A-Shelf (RAS) and is disclosed in confidence to the extent its subject matter is original to RAS. Any vendor receiving this drawing from RAS shall hold and use this drawing for the sole benefit of RAS and shall not disclose it to, or use or reproduce it for any third party, or perform any act adverse to the interest of RAS with respect to this drawing without the express written permission of RAS. Vendors shall not revise any physical, dimensional or performance characteristic unless authorized by Rev-A-Shelf Engineering.

REV.	DATE	BY	DESCRIPTION OF CHANGE
A	1/18/17	BKT	REVISED TO THE MOVENTO

INCH [MM]	AMERICAN PROJECTION	DRAWN	BY	DATE	REV-A-SHELF, INC.
			BKT	1/18/17	
			SIZE	DOUBLE 30 QUART WASTE CONTAINER BLUM SOFT CLOSE	
			MATERIAL	DRAWING NO.	SCALE
			FINISH	4WCSC-24DM2-SC_CUST	0.100
				PART NO.	SHEET 2 OF 2
			4WCSC-24DM2-SC_CUST		

TOLERANCES  
 MAT. DEC.  
 (WOOD) .XX ±.03 [.8mm]  
 (OTHER) .XX ±.02 [.5mm]  
 (ALL) .XXX ±.005 [.13 mm]  
 FRACTIONS ±1/32 [.8 mm]

ANGLES  
 ±1/2°