

CUSTOMER DRAWING

This drawing is the property of Rev-A-Shelf (RAS) and is disclosed in confidence to the extent its subject matter is original to RAS. Any vendor receiving this drawing from RAS shall hold and use this drawing for the sole benefit of RAS and shall not disclose it to, or use or reproduce it for any third party, or perform any act adverse to the interest of RAS with respect to this drawing without the express written permission of RAS. Vendors shall not revise any physical, dimensional or performance characteristic unless authorized by Rev-A-Shelf Engineering.

REV.	DATE	BY	DESCRIPTION OF CHANGE

INCH [MM]	AMERICAN PROJECTION 	BY	DATE	REV-A-SHELF, INC.	
		DRAWN	DKK 10/30/13	SIZE	B
TOLERANCES		MATERIAL	DRAWING NO.	SCALE	
MAT.	DEC.	FINISH	5190-15RM-1XX_CUST	0.188	
(WOOD)	.XX ±.03 [.8mm]		PART NO.	5190-15RM-1XX	SHEET OF
(OTHER)	.XX ±.02 [.5mm]				
(ALL)	.XXX ±.005 [.13 mm]				
FRACTIONS ±1/32 [.8 mm]					

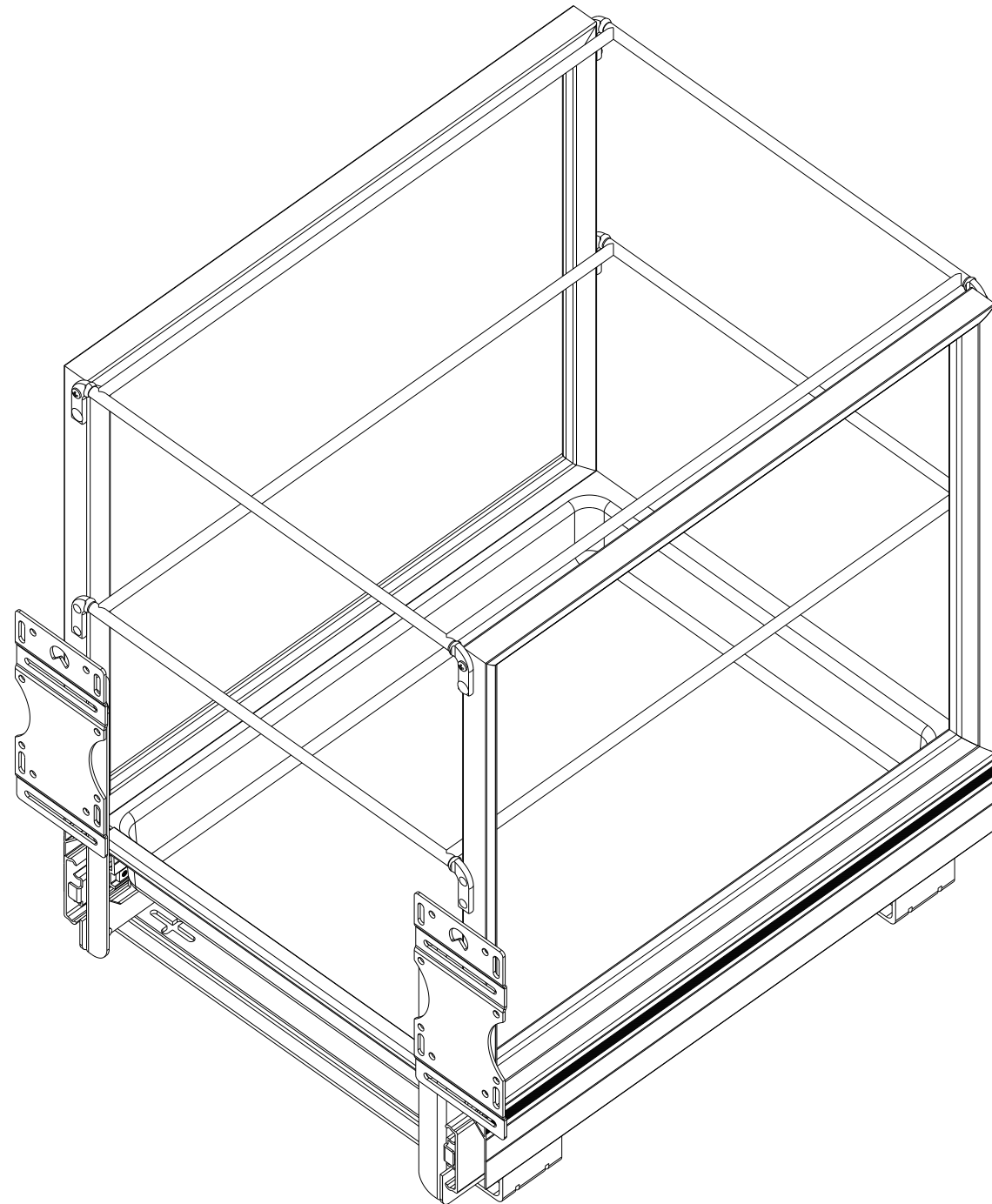

PART NO.	FINISH
5190-15RM-117	SILVER
5190-15RM-111	WHITE

PART DIMENSIONS	
WIDTH	14.29 [363,1]
DEPTH	18.07 [459,1]
HEIGHT	19.34 [491,2]
CONTAINER CAPACITY	2.1
CONTAINER UOM	BUSHEL

	MIN CABINET OPENING			
	FACE FRAME	FRAMELESS	INSET FACE FRAME	INSET FRAMELESS
WIDTH	14.50 [368,3]	14.50 [368,3]	14.50 [368,3]	14.50 [368,3]
DEPTH	18.13 [460,4]	18.13 [460,4]	18.88 [479,4]	18.88 [479,4]
HEIGHT	19.75 [501,7]	19.75 [501,7]	19.75 [501,7]	19.75 [501,7]

SLIDE SPECIFICATIONS				
SLIDE TYPE	BALL BEARING	SLIDE EXTENSION	FULL	MAX WEIGHT RATING
SLIDE CLOSING	N/A	SLIDE LENGTH	450 MM	
SLIDE MOUNTING	N/A	SLIDE FINISH	ZINC	150 LB

CUSTOMER DRAWING

This drawing is the property of Rev-A-Shelf (RAS) and is disclosed in confidence to the extent its subject matter is original to RAS. Any vendor receiving this drawing from RAS shall hold and use this drawing for the sole benefit of RAS and shall not disclose it to, or use or reproduce it for any third party, or perform any act adverse to the interest of RAS with respect to this drawing without the express written permission of RAS. Vendors shall not revise any physical, dimensional or performance characteristic unless authorized by Rev-A-Shelf Engineering.

REV.	DATE	BY	DESCRIPTION OF CHANGE

INCH [MM]	AMERICAN PROJECTION	DRAWN	BY	DATE	REV-A-SHELF, INC.
			DKK	10/30/13	
TOLERANCES		MATERIAL	FINISH	SIZE	ALUMINUM BOTTOM MOUNT CANVAS HAMPER
MAT.	DEC.			DRAWING NO.	SCALE
(WOOD) .XX ±.03 [8mm]	(OTHER) .XX ±.02 [5mm]	PART NO.	5190-15RM-1XX	5190-15RM-1XX_CUST	0.250
(ALL) .XXX ±.005 [13 mm]	FRACTIONS ±1/32 [8 mm]			SHEET	OF
				2	2