

CUSTOMER DRAWING

This drawing is the property of Rev-A-Shelf (RAS) and is disclosed in confidence to the extent its subject matter is original to RAS. Any vendor receiving this drawing from RAS shall hold and use this drawing for the sole benefit of RAS and shall not disclose it to, or use or reproduce it for any third party, or perform any act adverse to the interest of RAS with respect to this drawing without the express written permission of RAS. Vendors shall not revise any physical, dimensional or performance characteristic unless authorized by Rev-A-Shelf Engineering.

REV.	DATE	BY	DESCRIPTION OF CHANGE
C	12-19-17	KRR	ECN17-109
B	5/12/10	PFC	ECN10-054
A	3-5-10	KRR	ECN10-025

INCH [MM]	AMERICAN PROJECTION 	DRAWN	BY	DATE	REV-A-SHELF, INC.	
		PFC	PFC	9/18/08		
					SIZE	WASTE CONTAINER BOTTOM MOUNT DOUBLE 50 QT
					DRAWING NO.	4WCBM-2150DM-2
					SCALE	3:16
					PART NO.	4WCBM-2150DM-2
					SHEET OF	1 2

TOLERANCES
 MAT. DEC.
 (WOOD) .XX ±.03 [.8mm]
 (OTHER) .XX ±.02 [.5mm]
 (ALL) .XXX ±.005 [.13 mm]
 FRACTIONS ±1/32 [.8 mm]

ANGLES
 ±1/2°

MATERIAL

FINISH

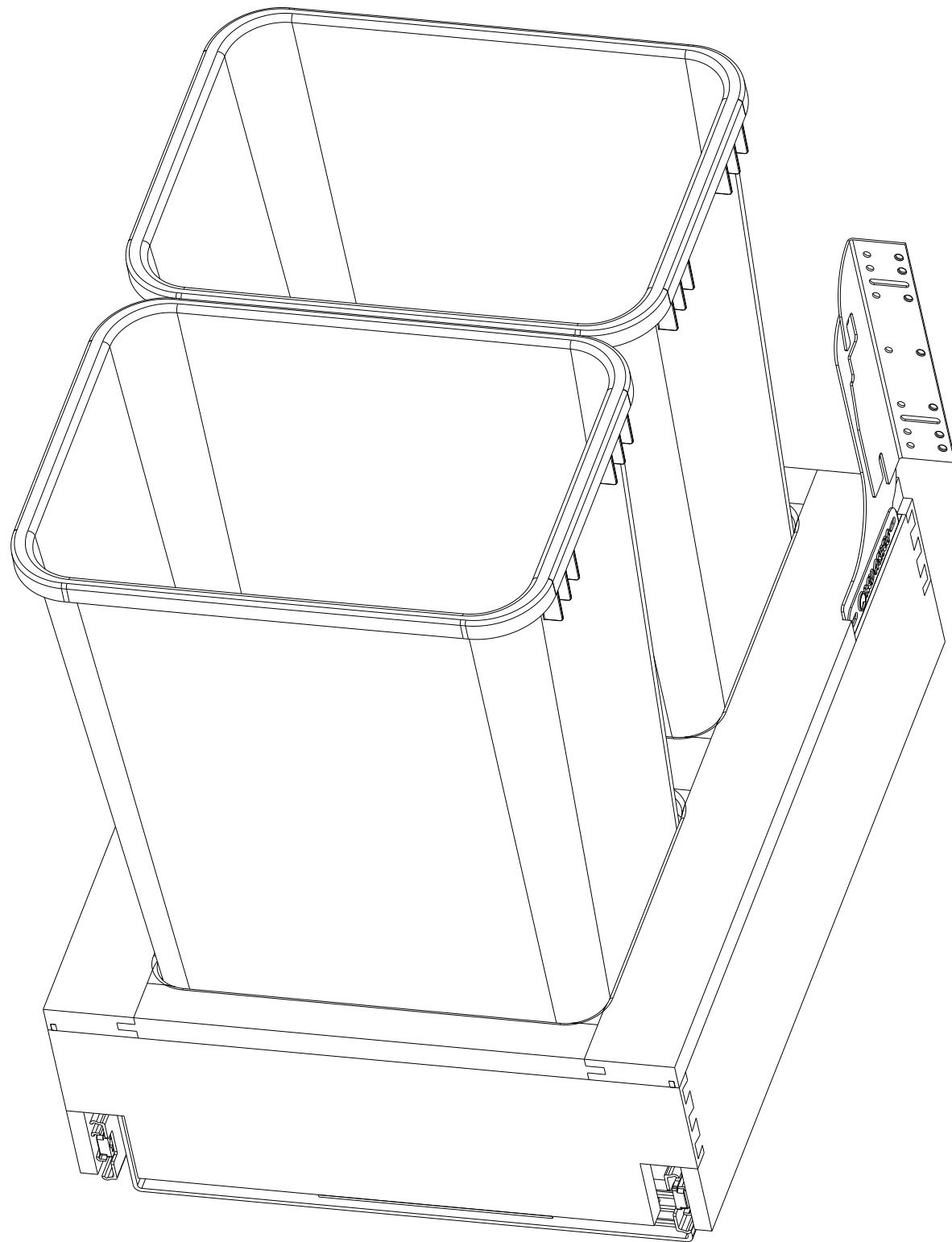

PART DIMENSIONS		
	MIN	MAX
WIDTH		17.25
DEPTH		21.65
HEIGHT		23.15
WEIGHT		
DIAMETER		
RADIUS		
CONTAINER CAPACITY	50	
CONTAINER UOM	QUART	

MIN CABINET OPENING				
	FACE FRAME	FRAMELESS	INSET FACE FRAME	INSET FRAMELESS
WIDTH	17.50	17.50	17.50	17.50
DEPTH	21.75	21.75	22.50	22.50
HEIGHT	23.50	23.50	23.50	23.50

SLIDE SPECIFICATIONS				
SLIDE TYPE	BALL BEARING	SLIDE EXTENSION	1 1/2" O.T.	MAX WEIGHT RATING
SLIDE CLOSING	REV-A-MOTION	SLIDE LENGTH	550 MM	
SLIDE MOUNTING		SLIDE FINISH	ZINC	150 LB

CUSTOMER DRAWING

This drawing is the property of Rev-A-Shelf (RAS) and is disclosed in confidence to the extent its subject matter is original to RAS. Any vendor receiving this drawing from RAS shall hold and use this drawing for the sole benefit of RAS and shall not disclose it to, or use or reproduce it for any third party, or perform any act adverse to the interest of RAS with respect to this drawing without the express written permission of RAS. Vendors shall not revise any physical, dimensional or performance characteristic unless authorized by Rev-A-Shelf Engineering.

REV.	DATE	BY	DESCRIPTION OF CHANGE
C	12-19-17	KRR	ECN17-109
B	5/12/10	PFC	ECN10-054
A	3-5-10	KRR	ECN10-025

INCH [MM]	AMERICAN PROJECTION	DRAWN	BY	DATE	REV-A-SHELF, Inc.	
			PFC	9/18/08	SIZE B	WASTE CONTAINER BOTTOM MOUNT DOUBLE 50 QT
TOLERANCES		MATERIAL		DRAWING NO.		SCALE
MAT. DEC. (WOOD) .XX ±.03 [.8mm] (OTHER) .XX ±.02 [.5mm] (ALL) .XXX ±.005 [.13 mm] FRACTIONS ±1/32 [.8 mm]		FINISH		4WCBM-2150DM-2		1:4
ANGLES ±1/2°				PART NO.		SHEET OF
				4WCBM-2150DM-2		2 2