

PART DIMENSIONS		
	MIN	MAX
WIDTH	14.77	
DEPTH	22.09	
HEIGHT	19.02	
CONTAINER CAPACITY	35	
CONTAINER UOM	QUART	

MIN CABINET OPENING				
	FACE FRAME	FRAMELESS	INSET FACE FRAME	INSET FRAMELESS
WIDTH	15.00	15.00	15.00	15.00
DEPTH	22.25	22.25	23.00	23.00
HEIGHT - *	20.50	20.50	20.50	20.50

* - MIN. CABINET HEIGHT INCLUDES LID (SOLD SEPERATELY)

SLIDE SPECIFICATIONS				
SLIDE MANUFACTURER		RELEASE PART NUMBER		
SLIDE TYPE	ALUMINUM	SLIDE EXTENSION	1.50 OT	MAX WEIGHT RATING
SLIDE CLOSING	SOFT	SLIDE LENGTH	22.00"	
SLIDE MOUNTING	BOTTOM	SLIDE FINISH	ALUMINUM	85 LB

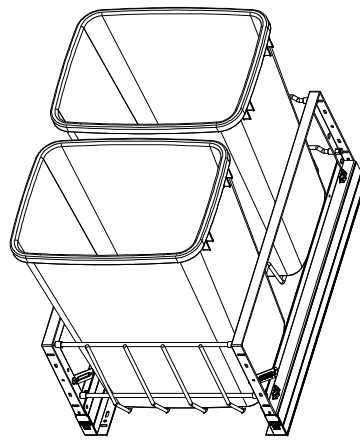
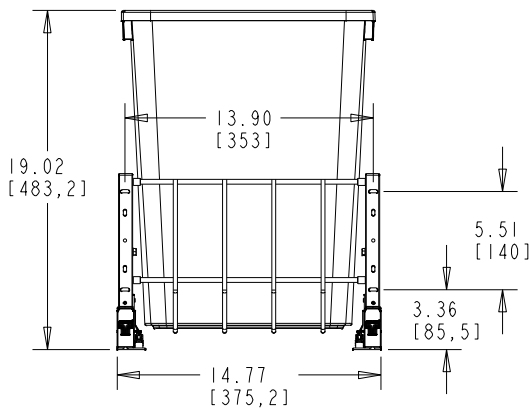

SCALE 0.125

CUSTOMER DRAWING

This drawing is the property of Rev-A-Shelf (RAS) and is disclosed in confidence to the extent its subject matter is original to RAS. Any vendor receiving this drawing from RAS shall hold and use this drawing for the sole benefit of RAS and shall not disclose it to, or use or reproduce it for any third party, or perform any act adverse to the interest of RAS with respect to this drawing without the express written permission of RAS. Vendors shall not revise any physical, dimensional or performance characteristic unless authorized by Rev-A-Shelf Engineering.

REV.	DATE	BY	DESCRIPTION OF CHANGE

INCH [MM]	AMERICAN PROJECTION	BY	DATE	REV-A-SHELF, INC.
		DRAWN	KRR 4-29-20	
MATERIAL				SIZE
FINISH				DOUBLE 35QT BOTTOM MOUNT
DRAWING NO.			SCALE	
5349-18DM-2			0.150	
PART NO.			SHEET	OF
5349-18DM-2			1	1