

PRODUCT



Catalog

Experience the Deerwood Difference



A Division of PAN AMERICAN SCREW

#1 RECEX
F-1R-7TI
< 0.075-0.08

(7.20)
(7.40)

520.010
REF

#2 ROBERTSON
F-2-9TI
PEN DEPTH < 1.91-2.03 >
0.075-0.08

16 TYPE 17
RUBRICIZE

DR. CH.X.L
DATE: 08/11/21
APP. CH.X.L
DATE: 08/11/21
DRAWING NO.
REVISION

(0.25)0.010
REF

9/16 TYPE 17
RUBRICIZE

eners
DR. CH.X.L
DATE: 08/11/21
APP. CH.X.L
DATE:

#1 RECEX
F-1R-7TI

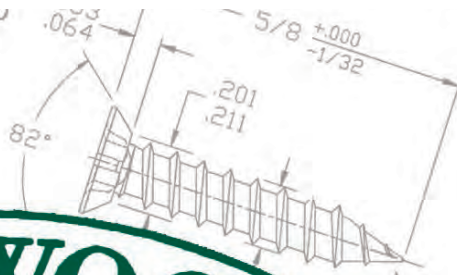

#2 RECEX
8-R-2R-9TI
PEN DEPTH < 0.075-0.080 >

ROUND/WASHER RECEX FULL S/TOOTH
STEEL, LUBRICIZE

THE INFORMATION AND DATA CONTAINED HEREIN IS THE SOLE PROPERTY OF ROBERTSON, INC. WE RESERVE ALL RIGHTS INCLUDING ANY REPRODUCTION, IN WHOLE OR IN PART, AND USE, IN ANY FORM IS STRICTLY PROHIBITED WITHOUT THE EXPRESS WRITTEN CONSENT OF ROBERTSON, INC.

erwood Fasteners
DR. CH.X.L
DATE: 09/05/14
APP. CH.X.L
DATE: 09/05/14
CUSTOMER
GROUP
DRAWING NO.
38554206012020

#7 PAN PHILLIPS 116 LO-ROOF

Deerwood Fasteners International Product Catalog

To our Current Customers - we appreciate your loyalty and continued support. We hope you'll enjoy our updated catalog and find the new products beneficial.

To our New Customers - Thank you for your interest. You will not be disappointed when you "Experience the Deerwood Difference." Deerwood Fasteners International is the leading supplier of High Quality Fasteners manufactured exclusively for woodworking applications. We service our nationwide customer base from our headquarters in Conover, NC and a regional warehouse in California. As you will see, our products include Hinge and Hardware Screws in a variety of finishes, Zip Drivers (Self-Drilling, Self-Countersinking Assembly Screws), Painted Head Cabinet Installation Screws, Decking Screws, Face Frame Screws, Drawer Front Adjuster Screws and much, much more. Our Inside Sales Staff is ready, willing and able to provide fast, efficient and knowledgeable service.

Call us at **1-800-438-5146** or visit us on the web at **www.deerwood.com**.

We Invite You To...

Experience Deerwood Quality, Service and Competitive Pricing for Yourself.



2039 American Avenue
Hayward, CA 94545

CORPORATE HEADQUARTERS
638 Reese Drive
Conover, NC 28613
800.438.5146
828-469-1075 (Local)
828-469-1050 (Fax)
828-466-0070 (Fax)





Table of Contents

Flat Head Phillips

Flat Head Phillips Twinfast Kwixin™ Wood	Page 1-2
Flat Head Phillips Deep Thread Type-17 Point Screws	
Flat Head Phillips Deep Thread Undercut Screws	
Flat Head Phillips Deep Thread Screws	

Flat Head Square

Flat Head Robertson® Square Twinfast Wood Screws	Page 3
Flat Head No. 2 Robertson® Square Deep Thread Screws	

Zip Drivers

Zip Drivers Deep Thread Screws with Nibs & Type-17 Point, Phillips or Robertson® Square	Page 4-5
Zip Drivers Flat Recex® Deep Thread Type-17 with Nibs	
WoodMaster™-Flat Recex®	

Round Washer Screws

Round Washer Deep Thread Screws	Page 6
WoodMaster™ - Round Washer Recex®	

Decking Screws

Flat Head Robertson® Square Deep Thread Nibs Type-17	Page 7-9
Stainless Steel	
Decking / Rustguard™ - Robertson® Square or Phillips Screws	
Copperguard Screws	

Truss / Modified Truss

Plated Cabinet Installation Screws	Page 10-11
Truss Head Phillips Deep Thread, Half Thread for Wood Studs	
Truss Head Phillips Deep Thread, Half Thread for Metal Studs	
Drill Point - For Heavier Gauge Metal Studs	
Recex® Cabinet Installation Plated	
Truss Head Phillips Type A & Deep Thread Tapping Screws	
Modified Truss Head Phillips Lg & X-Lg Washer Head Drawer Front Adjusting Screws	

Drawer Front Adjusting

Modified Truss - Phillips	Page 12
Modified Truss - Recex®	

Oval / Trim Head

Oval Head Phillips Deep Thread Screws	Page 13
Trim Head Robertson® Square Screws - Sharp Point	

Firmit Connecting Screws

“Firmit” Connecting Screws - Flat Head Pozi Drive	Page 14
---	---------

Machine Screws

Truss Head Machine Screws - Phillips/Slot Recess - Standard	Page 15
Truss Head Break-Away Machine Screws - Standard	

Pan Head Screws

Pan Head Phillips Type A Tapping & Deep Thread Screws	Page 16
Pan Head Robertson® Square Type A Tapping & Deep Thread Screws	

Face Frame Screws

Pan Head Square Fine Type-17	Page 17-18
Pan Head Phillips Fine Type-17	
Round Washer Recex® Deep Thread Type-17	
Pan Head Square Deep Thread Type-17	
Flat Top Pan Square XL Type-17 (PocketMaster®)	
Flat Top Pan Square Hi-Lo Type-17	
Flat Top Pan Square Fine Type-17	

Painted Head Screws

Painted Cabinet Installation Screws	Page 19
Truss Head Phillips Deep Thread, Half Thread for Wood Studs	
Truss Head Phillips Deep Thread, Half Thread for Metal Studs	
Drillpoint - For Heavier Gauge Metal Studs	

Euro Screws

Flat Head Pozi Drive/Phillips/Robertson® Square System Screws	Page 20
---	---------

Miscellaneous

Fastener Kits	Page 21-26
Woodmaster Jar Program	
Accessories	
Wood Fastener Guide	

Part Number Explanation

Factory Tour	Page 27-31
Notes	



Flat Head Phillips Screws

Flat Head Phillips



Flat Head Phillips Twinfast Kwixin™ Wood

Size	Part Number	Finish	Case QTY/WT
8 x 1	BFXA08100R2F	Black	11M/ctn-44 lbs
8 x 1-1/4	BFXA08114R2F	Black	9M/ctn-44 lbs
8 x 1-1/2	BFXA08112R2F	Black	7M/ctn-42 lbs
8 x 1-5/8	BFXA08158R2F	Black	5.5/ctn-34 lbs
8 x 2	BFXA08200R2F	Black	3.5M/ctn-27 lbs
8 x 2-1/4	BFXA08214R2F	Black	3M/ctn-27 lbs
8 x 2-3/4	BFXA08234R2F	Black	2.5M/ctn-28 lbs
8 x 3	BFXA08300R2F	Black	2M/ctn-22 lbs
9 x 1-1/4	BFXA09114R2F	Black	8M/ctn-47 lbs
9 x 1-1/2	BFXA09112R2F	Black	5M/ctn-33 lbs
9 x 1-3/4	BFXA09134R2F	Black	4.8M/ctn-36 lbs
9 x 2	BFXA09200R2F	Black	3.5M/ctn-31 lbs
9 x 3	BFXA09300R2F	Black	2M/ctn-23 lbs
10 x 1	BFXA10100R3F	Black	8M/ctn-44 lbs
10 x 1-1/2	BFXA10112R3F	Black	5M/ctn-42 lbs
10 x 2	BFXA10200R3F	Black	3.2M/ctn-33 lbs

For hardwood assembly applications. Thread design provides sufficient holding power in hard & softwoods.



Flat Phillips Deep Thread Undercut Screws

Size	Part Number	Finish	Case QTY/WT
6 x 1/2	BFXP06012U2Z	Zinc	38M/ctn-54 lbs
6 x 5/8	MFXP06058U2Z	Zinc	1M/box-1.7 lbs

Head designed to seat properly in smaller diameter countersunk holes. Used mainly with Asian manufactured European style drawer slides.



Flat Phillips Deep Thread Type-17 Point

Size	Part Number	Finish	Case QTY/WT
6 x 5/8	BFXP06058S2Z	Zinc	30M/ctn-52 lbs
6 x 5/8	BFXP06058S2N	Nickel	30M/ctn-52 lbs
6 x 5/8	MFXP06058S2N	Nickel	1M/box-1.7 lbs
6 x 3/4	BFXP06034S2Z	Zinc	24M/ctn-47 lbs
6 x 3/4	BFXP06034S2N	Nickel	24M/ctn-47 lbs
6 x 3/4	MFXP06034S2N	Nickel	1M/box-1.96 lbs

We use secondary machining operation to cut the Type-17 point into the thread before it is case hardened.

Flat Head Phillips Screws Available in the following...

- Flat Head Phillips Type A Tapping
- Flat Head Phillips Twinfast Wood
- Flat Phillips Deep Thread Type-17
- Flat Phillips Deep Thread Undercut

The professional woodworkers choice - our Lo-Root deep thread design provides maximum holding power in a variety of different woods and man-made materials. Excellent holding power in particleboard, MDF and even plastic composites. We have added an Extra- Deep Phillips Recess to help minimize bit slip-page; making this one of our most popular fasteners for the furniture and cabinet industry.



Flat Phillips Deep Thread Screws

Size	Part Number	Finish	Case QTY/WT
4 x 1/2	MFXP04012R1R	Brt Brass #1	1M/box-1 lbs
4 x 1/2	BFXP04012R1Z	Zinc #1	55M/ctn-51 lbs
4 x 5/8	BFXP04058R1Z	Zinc #1	45/ctn-53 lbs
4 x 5/8	MFXP04058R1Z	Zinc #1	1M/box-1.16 lbs
5 x 1/2	MFXP05012R2R	Brt Brass	1M/box-1.05 lbs
5 x 1/2	BFXP05012R2N	Nickel	40M/ctn-44 lbs
5 x 1/2	MFXP05012R2N	Nickel	1M/box-1.05lbs
5 x 1/2	BFXP05012R2Z	Zinc	40M/ctn-43 lbs
5 x 5/8	BFXP05058R2E	Ant. English	32M/ctn-41 lbs
5 x 5/8	MFXP05058R2F	Black	1M/box-1.3 lbs
5 x 5/8	BFXP05058R2R	Bright Brass	32M/ctn-41 lbs
5 x 5/8	MFXP05058R2R	Bright Brass	1M/box-1.3 lbs
5 x 5/8	BFXP05058R2N	Nickel	32M/ctn-42 lbs
5 x 5/8	MFXP05058R2N	Nickel	1M/box-1.3 lbs
5 x 5/8	BFXP05058R2Z	Zinc	32M/ctn-41 lbs
5 x 5/8	MFXP05058R2Z	Zinc	1M/box-1.3 lbs
6 x 7/16	BFXP06716R2Z	Zinc	38M/ctn-49 lbs

Flat Head Phillips Screws



Flat Head Phillips



Flat Phillips Deep Thread Screws			
Size	Part Number	Finish	Case QTY/WT
6 x 1/2	BFXP06012R2E	Ant. English	38M/ctn-54 lbs
6 x 1/2	BFXP06012R2F	Black	38M/ctn-54 lbs
6 x 1/2	BFXP06012R2N	Nickel	38M/ctn-54 lbs
6 x 1/2	MFXP06012R2N	Nickel	1M/box-1.5 lbs
6 x 1/2	BFXP06012R2C	White	38M/ctn-54 lbs
6 x 1/2	MFXP06012R2Z	Zinc	1M/box-1.42 lbs
6 x 5/8	BFXP06058R2E	Ant. English	30M/ctn-52 lbs
6 x 5/8	MFXP06058R2E	Ant. English	1M/box-1.7 lbs
6 x 5/8	BFXP06058R2F	Black	30M/ctn-49 lbs
6 x 5/8	BFXP06058R2R	Bright Brass	30M/ctn-52 lbs
6 x 5/8	MFXP06058R2R	Bright Brass	1M/box-1.7 lbs
6 x 5/8	BFXP06058R2N	Nickel	30M/ctn-52 lbs
6 x 5/8	CFXP06058R2N	Nickel	100 pc-.18 lbs
6 x 5/8	DFXP06058R2N	Nickel	500 pc-.85 lbs
6 x 5/8	LFXP06058R2N	Nickel	5M/box-8.64 lbs
6 x 5/8	MFXP06058R2N	Nickel	1M/box-1.7 lbs
6 x 5/8	BFXP06058R2S	Stat Bronze	30M/ctn-52 lbs
6 x 5/8	BFXP06058R2C	White	30M/ctn-52 lbs
6 x 5/8	CFXP06058R2Z	Zinc	100 pc-.18 lbs
6 x 5/8	MFXP06058R2Z	Zinc	1M/box-1.7 lbs
6 x 3/4	BFXP06034R2F	Black	24M/ctn-46 lbs
6 x 3/4	MFXP06034R2F	Black	1M/box-1.96 lbs
6 x 3/4	BFXP06034R2N	Nickel	24M/ctn-47 lbs
6 x 3/4	CFXP06034R2N	Nickel	100 pc-.21 lbs
6 x 3/4	MFXP06034R2N	Nickel	1M/box-1.96 lbs
6 x 3/4	LFXP06034R2N	Nickel	5M/box-10.17 lbs
6 x 3/4	BFXP06034R2Z	Zinc	24M/ctn-47 lbs
6 x 3/4	MFXP06034R2Z	Zinc	1M/box-1.96 lbs
6 x 1	BFXP06100R2F	Black	13.5M/ctn-35lbs
6 x 1	BFXP06100R2Z	Zinc	13.5M/ctn-35lbs
6 x 1	MFXP06100R2Z	Zinc	1M/box-2.52 lbs
6 x 1	BFXP06100R2N	Nickel	13.5M/ctn-35lbs
6 x 1	MFXP06100R2N	Nickel	1M/box-2 lbs
6 x 1-1/4	BFXP06114R2Z	Zinc	10.5M/ctn-32lbs
6 x 1-1/4	MFXP06114R2Z	Zinc	1M/box-3 lbs
6 x 1-1/2	BFXP06112R2F	Black	8.5M/ctn-32 lbs
6 x 1-1/2	BFXP06112R2Z	Zinc	8.5M/ctn-32 lbs
7 x 5/8	BFXP07058R2N	Nickel	24M/ctn-50 lbs
7 x 5/8	CFXP07058R2N	Nickel	100 pc-.79 lbs
7 x 5/8	MFXP07058R2N	Nickel	1M/box-1.88 lbs
7 x 3/4	BFXP07034R2N	Nickel	18M/ctn-44 lbs
7 x 3/4	CFXP07034R2N	Nickel	100 pc-.26 lbs
7 x 3/4	MFXP07034R2N	Nickel	1M/box-2.46lbs
8 x 1/2	BFXP08012R2Z	Zinc	20M/ctn-42 lbs
8 x 5/8	BFXP08058R2F	Black	18M/ctn-44 lbs
8 x 5/8	BFXP08058R2Z	Zinc	18M/ctn-44 lbs

- Smaller size screws used for attaching hardware parts to particleboard and softwoods.
- Larger size screws used for cabinet construction, furniture assembly. This type of screw is considered a coarse thread design.

Flat Phillips Deep Thread Screws			
Size	Part Number	Finish	Case QTY/WT
8 x 3/4	BFXP08034R2F	Black	15M/ctn-44 lbs
8 x 3/4	MFXP08034R2F	Black	1M/box-3 lbs
8 x 3/4	BFXP08034R2Z	Zinc	15M/ctn-42 lbs
8 x 3/4	MFXP08034R2Z	Zinc	1M/box-3lbs
8 x 7/8	BFXP08078R2F	Black	15M/ctn-48 lbs
8 x 1	BFXP08100R2F	Black	11M/ctn-40 lbs
8 x 1	MFXP08100R2F	Black	1M/box-3.6 lb
8 x 1	BFXP08100R2Z	Zinc	11M/ctn-40 lbs
8 x 1	MFXP08100R2Z	Zinc	1M/box-3.6 lbs
8 x 1-1/8	BFXP08118R2F	Black	10M/ctn-41 lbs
8 x 1-1/8	BFXP08118R2Z	Zinc	10M/ctn-41 lbs
8 x 1-1/4	BFXP08114R2F	Black	9M/ctn-40 lbs
8 x 1-1/4	MFXP08114R2F	Black	1M/box-4.4 lbs
8 x 1-1/4	BFXP08114R2Z	Zinc	9M/ctn-40 lbs
8 x 1-1/4	MFXP08114R2Z	Zinc	1M/box-4.4 lbs
8 x 1-3/8	BFXP08138R2F	Black	8M/ctn-39 lbs
8 x 1-3/8	BFXP08138R2Z	Zinc	8M/ctn-40 lbs
8 x 1-3/8	MFXP08138R2Z	Zinc	1M/box-4.9 lbs
8 x 1-1/2	BFXP08112R2F	Black	7M/ctn-36 lbs
8 x 1-1/2	MFXP08112R2F	Black	1M/box-5.14 lbs
8 x 1-1/2	BFXP08112R2Z	Zinc	7M/ctn-36 lbs
8 x 1-5/8	BFXP08158R2F	Black	5.5M/ctn-32 lbs
8 x 1-3/4	BFXP08134R2F	Black	4.8M/ctn-28 lbs
8 x 1-3/4	BFXP08134R2Z	Zinc	4.8M/ctn-28 lbs
8 x 2	BFXP08200R2F	Black	4M/ctn-28 lbs
8 x 2	MFXP08200R2F	Black	1M/ctn-7 lbs
8 x 2	BFXP08200R2Z	Zinc	4M/ctn-28 lbs
8 x 2	MFXP08200R2Z	Zinc	1M/box-7 lbs
8 x 2-1/4	BFXP08214R2F	Black	3.5M/ctn-27 lbs
8 x 2-1/4	MFXP08214R2Z	Zinc	3.5M/box-27 lbs
8 x 2-1/2	BFXP08212R2F	Black	2.5M/ctn-23 lbs
8 x 2-1/2	MFXP08212R2F	Black	1M/box-9 lbs
8 x 2-1/2	BFXP08212R2Z	Zinc	2.5M/ctn-23 lbs
8 x 2-3/4	BFXP08234R2F	Black	2.5M/ctn-23 lbs
8 x 3	BFXP08300R2F	Black	2M/ctn-23 lbs
8 x 3	MFXP08300R2F	Black	1M/ctn11 lbs
8 x 3	BFXP08300R2Z	Zinc	2M/ctn-23 lbs
9 x 1	BFXP09100R2F	Black	10M/ctn-43 lbs
9 x 1-1/4	BFXP09114R2F	Black	7M/ctn-37 lbs
9 x 1-1/2	BFXP09112R2F	Black	6M/ctn-37 lbs
9 x 2	BFXP09200R2F	Black	3.5M/ctn-29 lbs
9 x 2-1/2	BFXP09212R2F	Black	2.5M/ctn-25 lbs
9 x 3	BFXP09300R2F	Black	2M/ctn-25 lbs
10 x 3/4	BFXP10034R3F	Black	10M/ctn-38 lbs
10 x 1	BFXP10100R3F	Black	8M/ctn-42 lbs
10 x 1-1/4	BFXP10114R3F	Black	6M/ctn-38 lbs
10 x 1-1/2	BFXP10112R3F	Black	5M/ctn-38 lbs
10 x 1-3/4	BFXP10134R3F	Black	4M/ctn-35 lbs
10 x 2	BFXP10200R3F	Black	3.2M/ctn-29 lbs
10 x 2-1/2	BFXP10212R3F	Black	2M/ctn-23 lbs
10 x 3	BFXP10300R3F	Black	1.5M/ctn-22 lbs
10 x 3-1/2	BFXP10312R3F	Black	1M/box-16 lbs
10 x 4	BFXP10400R3Z	Zinc	1M/box-18 lbs

Flat Head Square Screws



Flat Head Square



Flat Head Robertson® Square Twinfast Wood Screws

Size	Part Number	Finish	Case QTY/WT
8 x 3/4	BFSA08034R2F	Black	15M/ctn-51 lbs
8 x 1-1/4	BFSA08114R2F	Black	9M/ctn-44 lbs
8 x 1-1/2	BFSA08112R2F	Black	7M/ctn-42 lbs
8 x 2	BFSA08200R2F	Black	4M/ctn-32 lbs
8 x 3	BFSA08300R2F	Black	2M/ctn-24 lbs
12 x 1-1/2	BFSA12112R3L	Lube	3M/ctn-33 lbs
12 x 2	BFSA12200R3L	Lube	2M/ctn-30 lbs
12 x 2-1/2	BFSA12212R3L	Lube	5M/ctn-26 lbs
12 x 3	BFSA12300R3L	Lube	1M/ctn-20 lbs
12 x 3-1/2	BFSA12312R3L	Lube	800pcs-19 lbs
12 x 4	BFSA12400R3L	Lube	500pcs-15 lbs
14 x 3	BFSA14300R3L	Lube	500pcs-19 lbs

For hardwood fastening applications.

Flat Head Robertson® Square Twinfast Wood Screws

Provides maximum bit fit and helps eliminate driver bit camout. The double lead thread starts quickly and drives faster than most single lead thread designs. Excellent choice for hardwood fastening applications.

QUALITY We manufacture our screws in our factory, this gives our fasteners a consistent high quality. Every shipment under goes a rigorous quality control inspection at our factory and again upon arrival at our warehouse.



Flat Head No. 2 Robertson® Square Deep Thread Screws

Size	Part Number	Finish	Case QTY/WT
6 x 1/2	BFSP06012R2Z	Zinc	38M/ctn-54 lbs
6 x 5/8	BFSP06058R2Z	Zinc	30M/ctn-48 lbs
6 x 3/4	BFSP06034R2Z	Zinc	24M/ctn-54 lbs
6 x 1	BFSP06100R2Z	Zinc	13.5M/ctn-35 lbs
6 x 1-1/4	BFSP06114R2Z	Zinc	10.5M/ctn-33 lbs
6 x 1-1/2	BFSP06112R2Z	Zinc	8.5M/ctn-33 lbs
8 x 3/4	BFSP08034R2F	Black	15M/ctn-42 lbs
8 x 3/4	BFSP08034R2Z	Zinc	15M/ctn-42 lbs
8 x 1	BFSP08100R2F	Black	11M/ctn-40 lbs
8 x 1	MFSP08100R2F	Black	1M/box 3.6 lbs
8 x 1	BFSP08100R2Z	Zinc	11M/ctn-40 lbs
8 x 1-1/4	BFSP08114R2F	Black	9M/ctn-41 lbs
8 x 1-1/4	MFSP08114R2F	Black	1M/box 4.6 lbs
8 x 1-1/4	BFSP08114R2Z	Zinc	9M/ctn-41 lbs
8 x 1-1/2	BFSP08112R2F	Black	7M/ctn-36 lbs
8 x 1-1/2	MFSP08112R2F	Black	1M/box-5.14 lbs
8 x 1-1/2	BFSP08112R2Z	Zinc	7M/ctn-36 lbs
8 x 1-5/8	BFSP08158R2F	Black	5.5M/ctn-33 lbs
8 x 1-3/4	BFSP08134R2F	Black	4M/ctn-24 lbs
8 x 1-3/4	MFSP08134R2F	Black	1M/box-6 lbs
8 x 1-3/4	BFSP08134R2Z	Zinc	4M/ctn-24 lbs
8 x 2	BFSP08200R2F	Black	3M/ctn-20 lbs
8 x 2	BFSP08200R2Z	Zinc	3M/ctn-21 lbs

Flat Head No. 2 Robertson® Square Deep Thread Screws

Size	Part Number	Finish	Case QTY/WT
8 x 2-1/4	BFSP08214R2F	Black	4M/ctn 31 lbs
8 x 2-1/2	BFSP08212R2F	Black	2.8M/ctn-26 lbs
8 x 2-1/2	BFSP08212R2Z	Zinc	2.8M/ctn-26 lbs
8 x 3	BFSP08300R2F	Black	2M/ctn-23 lbs
8 x 3	MFSP08300R2F	Black	1M/box-11 lbs
8 x 3	BFSP08300R2Z	Zinc	2M/ctn-23 lbs
9 x 1-1/2	BFSP09112R2F	Black	7M/ctn-44 lbs
10 x 1-1/4	BFSP10114R2F	Black	6M/ctn-36 lbs
10 x 1-1/2	BFSP10112R2F	Black	5M/ctn-36 lbs
10 x 1-3/4	BFSP10134R2F	Black	4M/ctn-35 lbs
10 x 2	BFSP10200R2F	Black	3.2M/ctn-29 lbs
10 x 2-1/2	BFSP10212R2F	Black	2M/ctn-24 lbs
10 x 3	BFSP10300R2F	Black	1.5M/ctn-21 lbs
10 x 3-1/2	BFSP10312R2L	Lube	1M/ctn-16 lbs
10 x 4	BFSP10400R2L	Lube	1M/ctn-19 lbs

Flat Head No. 2 Robertson® Square Deep Thread Screws

This screw combines the positive drive of the Robertson® Square Recess with the versatility of our deep thread design, sizes from #6 through #10 with a standard #2 square drive so you do not waste time switching driver bits.



Zip Drivers

Zip Driver Screws Available in the following...

- Zip Driver Flat Head Deep Thread Screws with Nibs and Type 17 Point - Phillips Recess
- Zip Driver Flat Head Deep Thread Screws with Nibs and Type 17 Point - Robertson® Square Recess
- Zip Driver Flat Head Deep Thread Screws with Nibs and Type 17 Point - Recex®

The Zip Driver is considered to be our Ultimate Wood Screw!



Zip Driver Phillips Recess

Size	Part Number	Finish	Case QTY/WT
8 x 1	BFXP08100SNF	Black	11M/ctn-39 lbs
8 x 1	MFSP08100SNF	Black	1M/box-3.64 lbs
8 x 1	BFXP08100SNZ	Zinc	11M/ctn-39 lbs
8 x 1	MFSP08100SNZ	Zinc	1M/box-3.64 lbs
8 x 1-1/4	BFXP08114SNF	Black	9M/ctn-40 lbs
8 x 1-1/4	MFSP08114SNF	Black	1M/box-4.44 lbs
8 x 1-1/4	BFXP08114SNZ	Zinc	9M/ctn-40 lbs
8 x 1-1/4	MFSP08114SNZ	Zinc	1M/box-4.44 lbs
8 x 1-1/2	BFXP08112SNF	Black	7M/ctn-37 lbs
8 x 1-1/2	MFSP08112SNF	Black	1M/box 5.29 lbs
8 x 1-1/2	BFXP08112SNZ	Zinc	7M/ctn-37 lbs
8 x 1-1/2	MFSP08112SNZ	Zinc	1M/box-5.29 lbs
8 x 1-5/8	BFXP08158SNF	Black	5.5M/ctn-30 lbs
8 x 1-5/8	MFSP08158SNF	Black	1M/box-5.82 lbs
8 x 1-5/8	BFXP08158SNZ	Zinc	5.5M/ctn-32 lbs
8 x 1-5/8	MFSP08158SNZ	Zinc	1M/box-5.82 lbs
8 x 1-3/4	BFXP08134SNF	Black	4.8M/ctn-29 lbs
8 x 1-3/4	MFSP08134SNF	Black	1M/box-6.04 lbs
8 x 1-3/4	BFXP08134SNZ	Zinc	4.8M/ctn-29 lbs
8 x 1-3/4	MFSP08134SNZ	Zinc	1M/box-6.04 lbs
8 x 2	BFXP08200SNF	Black	4M/ctn-28 lbs
8 x 2	MFSP08200SNF	Black	1M/box-7 lbs
8 x 2	BFXP08200SNZ	Zinc	4M/ctn-28 lbs
8 x 2	MFSP08200SNZ	Zinc	1M/box-7 lbs
8 x 2-1/4	BFXP08214SNF	Black	3.5M/ctn-27 lbs
8 x 2-1/4	MFSP08214SNF	Black	1M/box-7.71 lbs
8 x 2-1/4	BFXP08214SNZ	Zinc	3.5M/ctn-27 lbs
8 x 2-1/4	MFSP08214SNZ	Zinc	1M/box-7.71 lbs
8 x 2-1/2	BFXP08212SNF	Black	2.5M/ctn-22 lbs
8 x 2-1/2	MFSP08212SNF	Black	1M/box-9.2 lbs
8 x 2-1/2	BFXP08212SNZ	Zinc	2.5M/ctn-22 lbs
8 x 2-1/2	MFSP08212SNZ	Zinc	1M/box-9.2 lbs
8 x 3	BFXP08300SNF	Black	2M/ctn-22 lbs
8 x 3	MFSP08300SNF	Black	1M/box-11.5 lbs
8 x 3	BFXP08300SNZ	Zinc	2M/ctn-22 lbs
8 x 3	MFSP08300SNZ	Zinc	1M/box-11.5 lbs

We start with an Extra Deep Phillips Recess, then we added self-countersinking nibs under the head that carve away the material. Next we added a Type-17 self-drilling point to our popular deep thread design that practically eliminates splitting and bursting in most species of wood and man-made materials.

Zip Driver Square Recess-Flat Head Robertson®

Size	Part Number	Finish	Case QTY/WT
8 x 1	BFSP08100SNF	Black	11M/ctn-40 lbs
8 x 1	MFSP08100SNF	Black	1M/box-3.64 lbs
8 x 1	BFSP08100SNZ	Zinc	11M/ctn-40 lbs
8 x 1	MFSP08100SNZ	Zinc	1M/box-3.64 lbs
8 x 1-1/4	BFSP08114SNF	Black	9M/ctn-38 lbs
8 x 1-1/4	MFSP08114SNF	Black	1M/box-4.44 lbs
8 x 1-1/4	BFSP08114SNZ	Zinc	9M/ctn-38 lbs
8 x 1-1/4	MFSP08114SNZ	Zinc	1M/box-4.44 lbs
8 x 1-1/2	BFSP08112SNF	Black	7M/ctn-35 lbs
8 x 1-1/2	MFSP08112SNF	Black	1M/box 5.29 lbs
8 x 1-1/2	BFSP08112SNZ	Zinc	7M/ctn-35 lbs
8 x 1-1/2	MFSP08112SNZ	Zinc	1M/box-5.29 lbs
8 x 1-5/8	BFSP08158SNF	Black	5.5M/ctn-36 lbs
8 x 1-5/8	MFSP08158SNF	Black	1M/box-5.82 lbs
8 x 1-5/8	BFSP08158SNZ	Zinc	5.5M/ctn-36 lbs
8 x 1-5/8	MFSP08158SNZ	Zinc	1M/box-5.82 lbs
8 x 1-3/4	BFSP08134SNF	Black	4.8M/ctn-31 lbs
8 x 1-3/4	MFSP08134SNF	Black	1M/box-6.04 lbs
8 x 1-3/4	BFSP08134SNZ	Zinc	4.8M/ctn-31 lbs
8 x 1-3/4	MFSP08134SNZ	Zinc	1M/box-6.04 lbs
8 x 2	BFSP08200SNF	Black	4M/ctn-26 lbs
8 x 2	MFSP08200SNF	Black	1M/box-7 lbs
8 x 2	BFSP08200SNZ	Zinc	4M/ctn-26 lbs
8 x 2	MFSP08200SNZ	Zinc	1M/box-7 lbs
8 x 2-1/4	BFSP08214SNF	Black	3.5M/ctn-25 lbs
8 x 2-1/4	MFSP08214SNF	Black	1M/box-7.71 lbs
8 x 2-1/4	BFSP08214SNZ	Zinc	3.5M/ctn-25 lbs
8 x 2-1/4	MFSP08214SNZ	Zinc	1M/box-7.71 lbs
8 x 2-1/2	BFSP08212SNF	Black	2.5M/ctn-25 lbs
8 x 2-1/2	MFSP08212SNF	Black	1M/box-9.2 lbs
8 x 2-1/2	BFSP08212SNZ	Zinc	2.5M/ctn-25 lbs
8 x 2-1/2	MFSP08212SNZ	Zinc	1M/box-9.2 lbs
8 x 3	BFSP08300SNF	Black	2M/ctn-21 lbs
8 x 3	MFSP08300SNF	Black	1M/box-11.5 lbs
8 x 3	BFSP08300SNZ	Zinc	2M/ctn-21 lbs
8 x 3	MFSP08300SNZ	Zinc	1M/box-11.5 lbs

Our Square Drive Zip Drivers combines the Type-17 self-drilling point that pre-drills itself with the original Robertson® Square Drive Recess for optimum performance. We then added the nibs under the head to help make this a true “One-Step” fastener. Simply put one on the driver bit and watch it pre-drill and self-countersink itself in most all types of wood. We have combined all of our most popular features into one product and it is quickly becoming the fastener of choice.

Zip Driver



Zip Driver Recex® Recess

Size	Part Number	Finish	Case QTY/WT
6 x 1/2	BFRP06012S2L	Lube	15M/ctn-21 lbs
6 x 5/8	BFRP06058S2L	Lube	15M/ctn-25 lbs
6 x 3/4	BFRP06034S2L	Lube	15M/ctn-30 lbs
6 x 1-1/4	BFRP06114S2L	Lube	8M/ctn-32 lbs
8 x 7/8	BFRP08078S2L	Lube	15M/ctn-34 lbs
8 x 1	BFRP08100SNF	Black	11M/ctn-40 lbs
8 x 1	MFRP08100SNF	Black	1M/box-3.64 lbs
8 x 1	BFRP08100SNZ	Zinc	11M/ctn-40 lbs
8 x 1	MFRP08100SNZ	Zinc	1M/box-3.64 lbs
8 x 1	BFRP08100SNL	Lube	10M/ctn-38 lbs
8 x 1-1/4	BFRP08114SNF	Black	9M/ctn-38 lbs
8 x 1-1/4	MFRP08114SNF	Black	1M/box-4.44 lbs
8 x 1-1/4	BFRP08114SNZ	Zinc	9M/ctn-38 lbs
8 x 1-1/4	MFRP08114SNZ	Zinc	1M/box-4.44 lbs
8 x 1-1/4	BFRP08114SNL	Lube	9M/ctn-37 lbs
8 x 1-3/8	BFRP08138SNL	Lube	5M/ctn-33 lbs
8 x 1-1/2	BFRP08112SNF	Black	7M/ctn-35 lbs
8 x 1-1/2	MFRP08112SNF	Black	1M/box-5.29 lbs
8 x 1-1/2	BFRP08112SNZ	Zinc	7M/ctn-35 lbs
8 x 1-1/2	MFRP08112SNZ	Zinc	1M/box-5.29 lbs
8 x 1-1/2	BFRP08112SNL	Lube	7M/ctn-28 lbs
8 x 1-5/8	BFRP08158SNF	Black	5.5M/ctn-36 lbs
8 x 1-5/8	MFRP08158SNF	Black	1M/box-5.82 lbs
8 x 1-5/8	BFRP08158SNZ	Zinc	5.5M/ctn-36 lbs
8 x 1-5/8	MFRP08158SNZ	Zinc	1M/box-5.82 lbs
8 x 1-3/4	BFRP08134SNF	Black	4.8M/ctn-31 lbs
8 x 1-3/4	MFRP08134SNF	Black	1M/box-6.04 lbs
8 x 1-3/4	BFRP08134SNZ	Zinc	4.8M/ctn-31 lbs
8 x 1-3/4	MFRP08134SNZ	Zinc	1M/box-6.04 lbs
8 x 1-3/4	BFRP08134SNL	Lube	4M/ctn-25 lbs
8 x 2	BFRP08200SNF	Black	4M/ctn-20 lbs
8 x 2	MFRP08200SNF	Black	1M/box-7 lbs
8 x 2	BFRP08200SNZ	Zinc	4M/ctn-20 lbs
8 x 2	MFRP08200SNZ	Zinc	1M/box-7 lbs
8 x 2	BFRP08200SNL	Lube	4M/ctn-25 lbs
8 x 2-1/4	BFRP08214SNF	Black	3.5M/ctn-25 lbs
8 x 2-1/4	MFRP08214SNF	Black	1M/box-7.71 lbs
8 x 2-1/4	BFRP08214SNZ	Zinc	3.5M/ctn-25 lbs
8 x 2-1/4	MFRP08214SNZ	Zinc	1M/box-7.71 lbs
8 x 2-1/4	BFRP08214SNL	Lube	3M/ctn-24 lbs
8 x 2-1/2	BFRP08212SNF	Black	2.5M/ctn-23 lbs
8 x 2-1/2	MFRP08212SNF	Black	1M/box-9.2 lbs
8 x 2-1/2	BFRP08212SNZ	Zinc	2.5M/ctn-23 lbs
8 x 2-1/2	MFRP08212SNZ	Zinc	1M/box-9.2 lbs
8 x 2-1/2	BFRP08212SNL	Lube	2.5M/ctn-22 lbs
8 x 2-3/4	BFRP08234SNF	Black	2.5M/ctn-23 lbs
8 x 2-3/4	BFRP08234SNZ	Zinc	2.5M/ctn-23 lbs
8 x 2-3/4	BFRP08234SNL	Lube	2M/ctn-20 lbs
8 x 3	BFRP08300SNF	Black	2M/ctn-22 lbs
8 x 3	MFRP08300SNF	Black	1M/box-11.5 lbs
8 x 3	BFRP08300SNZ	Zinc	2M/ctn-22 lbs
8 x 3	MFRP08300SNZ	Zinc	1M/box-11.5 lbs
8 x 3	BFRP08300SNL	Lube	2M/ctn-16 lbs
8 x 3-1/2	BFRP08312SNL	Lube	1M/ctn-13 lbs
10 x 3-1/2	BFRP10312SNL	Lube	1M/ctn-17 lbs

It doesn't get any better than this!

This is our most popular new product. We have taken the Recex® Square-Phillips Combination Recess and combined it with our popular Zip Driver product line. The dependable Type-17 point pre-drills the wood while the nibs underneath the head allow the fastener to self-countersink itself into all types of soft and hardwoods. The patented Recex® Square-Phillips Combo Recess insures you always have the correct driver bit to install or adjust your finished wood working project.



Flat Recex® WoodMaster™ with Nibs

Size	Part Number	Finish	Case QTY/WT
8 x 5/8	BFRW08058R2L	Lube	15M/ctn-40 lbs
8 x 3/4	BFRW08034R2L	Lube	15M/ctn-38 lbs
8 x 1	BFRW08100R2L	Lube	10M/ctn-35 lbs
8 x 1-1/8	BFRW08118R2L	Lube	8M/ctn-34 lbs
8 x 1-1/4	BFRW08114R2L	Lube	7.5M/ctn-33 lbs
8 x 1-3/8	BFRW08138R2L	Lube	5M/ctn-26 lbs
8 x 1-1/2	BFRW08112R2L	Lube	5M/ctn-25 lbs
8 x 1-3/4	BFRW08134R2L	Lube	4M/ctn-24 lbs
8 x 2	BFRW08200R2L	Lube	3.5M/ctn-24 lbs
8 x 2-1/4	BFRW08214R2L	Lube	3M/ctn-24 lbs
8 x 2-1/2	BFRW08212R2L	Lube	2.5M/ctn-21 lbs
8 x 2-1/2	MFRW08212R2L	Lube	1M/ctn-8 lbs
8 x 2-3/4	BFRW08234R2L	Lube	2M/ctn-20 lbs
8 x 3	BFRW08300R2L	Lube	1.5M/ctn-15 lbs

Zip Driver

**Self-Drilling and
Self-Countersinking
into most all woods.**





Round Washer Screws



Round Washer Recex® Deep Thread Screws

Size	Part Number	Finish	Case QTY/WT
8 x 5/8	BWRP08058R2Z	Zinc	12M/ctn-42 lbs
8 x 1	BWRP08100R2F	Black	8M/ctn-41 lbs
8 x 1	BWRP08100R2Z	Zinc	8M/ctn-41 lbs
8 x 1-1/8	BWRP08118R2Z	Zinc	6M/ctn-32 lbs
8 x 1-1/4	BWRP08114R2F	Black	6M/ctn-36 lbs
8 x 1-1/4	BWRP08114R2Z	Zinc	6M/ctn-36 lbs
8 x 1-1/2	BWRP08112R2F	Black	5M/ctn-31 lbs
8 x 1-1/2	BWRP08112R2Z	Zinc	5M/ctn-31 lbs
8 x 2	BWRP08200R2F	Black	3M/ctn-27 lbs
8 x 2	BWRP08200R2Z	Zinc	3M/ctn-27 lbs
8 x 2-1/2	BWRP08212R2F	Black	2M/ctn-23 lbs
8 x 2-1/2	BWRP08212R2Z	Zinc	2M/ctn-23 lbs
8 x 2-1/2	MWRP08212R2Z	Zinc	1M/box-10.5 lbs
8 x 3	BWRP08300R2F	Black	1.5M/ctn-20 lbs
8 x 3	BWRP08300R2Z	Zinc	1.5M/ctn-20 lbs
8 x 3	MWRP08300R2Z	Zinc	1M/box-12.8 lbs



Round Washer Recex® Type 17 Point

Size	Part Number	Finish	Case QTY/WT
8 x 7/8	BWRP08078S2L	Lube	8M/ctn
8 x 1	BWRP08100S2L	Lube	8M/ctn
8 x 1-1/8	BWRP08118S2L	Lube	6M/ctn
8 x 1-1/4	BWRP08114S2L	Lube	6M/ctn
8 x 1-1/2	BWRP08112S2L	Lube	5M/ctn
8 x 1-3/4	BWRP08134S2L	Lube	4M/ctn
8 x 2	BWRP08200S2L	Lube	3M/ctn
8 x 2-1/2	BWRP08212S2L	Lube	2M/ctn
8 x 3	BWRP08300S2L	Lube	1.5M/ctn



WoodMaster™ Round Washer Recex®

Size	Part Number	Finish	Case QTY/WT
8 x 3/4	BWRW08034R2L	Lube	10M/ctn
8 x 1	BWRW08100R2L	Lube	8M/ctn
8 x 1-1/8	BWRW08118R2L	Lube	6M/ctn
8 x 1-1/4	BWRW08114R2L	Lube	6M/ctn
8 x 1-3/8	BWRW08138R2L	Lube	5M/ctn
8 x 1-1/2	BWRW08112R2L	Lube	5M/ctn
8 x 1-3/4	BWRW08134R2L	Lube	4M/ctn
8 x 2	BWRW08200R2L	Lube	3M/ctn
8 x 2-1/4	BWRW08214R2L	Lube	2M/ctn
8 x 2-1/2	BWRW08212R2L	Lube	2M/ctn
8 x 2-3/4	BWRW08234R2L	Lube	1.5M/ctn
8 x 3	BWRW08300R2L	Lube	1.5M/ctn

Patented serrated thread design slices through even the hardest materials to eliminate splitting.

Round Washer Screws Available in the following...

- Round Washer Head Deep Thread Screw Recex® Recess
- WoodMaster™ - Round Washer Recex®
- Round Washer Head Deep Thread Screw Recex® Recess Type 17



Round Washer Recex® Deep Thread Screws

Size	Part Number	Finish	Case QTY/WT
6 x 5/8	BWRP06058R1L	Lube	15M/ctn-36 lbs
8 x 1/2	BWRP08012R2L	Lube	12M/ctn-36 lbs
8 x 5/8	BWRP08058R2L	Lube	12M/ctn-48 lbs
8 x 3/4	BWRP08034R2L	Lube	10M/ctn-40 lbs
8 x 7/8	BWRP08078R2L	Lube	8M/ctn-35 lbs
8 x 1	BWRP08100R2L	Lube	8M/ctn-38 lbs
8 x 1-1/8	BWRP08118R2L	Lube	6M/ctn-31 lbs
8 x 1-1/4	BWRP08114R2L	Lube	6M/ctn-33 lbs
8 x 1-3/8	BWRP08138R2L	Lube	5M/ctn-30 lbs
8 x 1-1/2	BWRP08112R2L	Lube	5M/ctn-32 lbs
8 x 1-3/4	BWRP08134R2L	Lube	4M/ctn-27 lbs
8 x 2	BWRP08200R2L	Lube	3M/ctn-23 lbs
8 x 2-1/4	BWRP08214R2L	Lube	2M/ctn-19 lbs
8 x 2-1/2	BWRP08212R2L	Lube	2M/ctn-21 lbs
8 x 3	BWRP08300R2L	Lube	1.5M/ctn-18 lbs
8 x 3-1/2	BWRP08312R2L	Lube	1M/ctn-14 lbs
8 x 4	BWRP08400R2L	Lube	800pcs-13 lbs
10 x 5/8	BWRP10058R2L	Lube	8M/ctn-40 lbs
10 x 3/4	BWRP10034R2L	Lube	8M/ctn-44 lbs
10 x 1	BWRP10100R2L	Lube	6M/ctn-39 lbs
10 x 1-1/4	BWRP10114R2L	Lube	5M/ctn-38 lbs
10 x 1-1/2	BWRP10112R2L	Lube	3M/ctn-28 lbs
10 x 1-3/4	BWRP10134R2L	Lube	3M/ctn-30 lbs
10 x 2	BWRP10200R2L	Lube	2.5M/ctn-27 lbs
10 x 2-1/2	BWRP10212R2L	Lube	1.5M/ctn-20 lbs
10 x 3	BWRP10300R2L	Lube	1M/ctn-16 lbs
10 x 4	BWRP10400R2L	Lube	800pcs-19 lbs

The Round Washer Head design could possibly be the most versatile head design available. It combines the advantages of the Pan Head design but has a washer built on to the head to increase head diameter and prevent overdriving in softwoods. General cabinet assembly, installation, hinges, metal drawer slides, wooden drawer guides, attaching lights and brackets are just a few applications where the Round Washer Head design is used. The addition of the washer provides maximum bearing surface to allow for "overdriving" the screw to tighten those stubborn joints with ease.



Seamaster™ Screws			
Size	Part Number	Finish	Case QTY/WT
7 x 1-1/4	114SEA	Stainless	Steel 8M/box-451bs
7 x 1-5/8	158SEA	Stainless	Steel 5M/box-271bs
8 x 2	2SEA	Stainless	Steel 3M/box-231bs
9 x 2-1/2	212SEA	Stainless	Steel 2M/box-221bs
10 x 3	3SEA	Stainless	Steel 2M/box-311bs
10 x 3-1/2	312SEA	Stainless	Steel 1M/box-181bs
10 x 4	4SEA	Stainless	Steel 1M/box-211bs
10 x 5	5SEA	Stainless	Steel 500/box-181bs

**Flat Robertson® Square Deep Thread Nibs Type 17
Stainless Steel Screws**



- Flat head design with self-countersinking nibs provides a finished look in one step.
- Genuine Robertson® square drive recess eliminates bit slippage and camout.
- Deep thread design offers maximum holding power.
- Type-17 self-drilling point eliminates splitting.
- 305 grade stainless steel provides more strength and corrosion resistance.

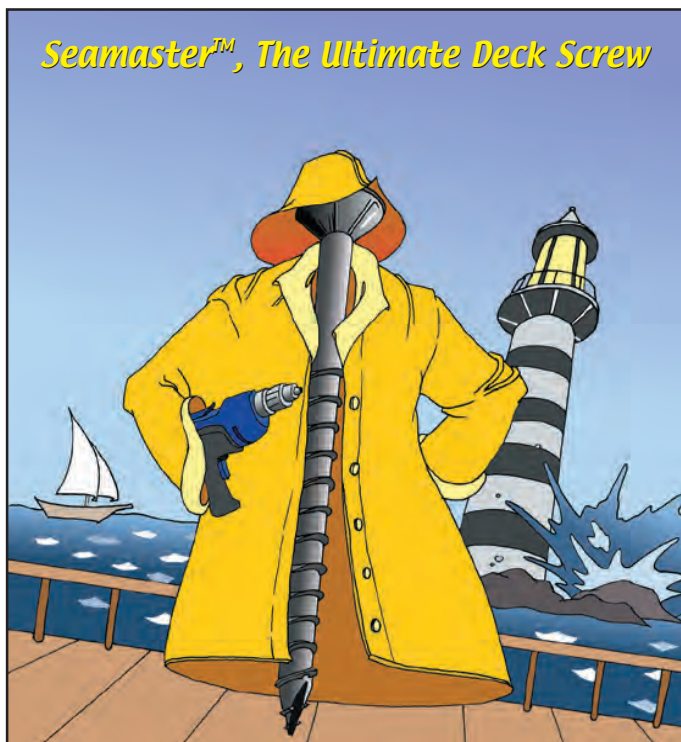

For the “ultimate” in corrosion protection try our Seamaster™ line. We have added many features and benefits to this line, making it one of our most popular products. We use only high grade 305 stainless steel to produce our Seamaster™ line. We start with aggressive deep thread design and a Type-17 self-drilling cutter point to reduce driving torque and eliminate splitting and bursting. Next, we add a flat head design with nibs built under the head to self-countersink the screw without the need for pre-boring. Finally we have utilized the original Robertson® square drive recess for optimal performance and driver bit engagement. If you want the highest quality fastener available for use in your outdoor project, our Seamaster™ line is second to none.

Decking Screws



Rustguard™ Square and Phillips Screws



Rustguard™ – Robertson® Square Head

Size	Part Number	Finish	Case QTY/WT
7 x 2	2SRG	Silver	3.5M/ctn-24 lbs
8 x 2-1/2	212SRG	Silver	2.5M/ctn-28 lbs
9 x 3	3SRG	Silver	2M/ctn-25 lbs
10 x 3-1/2	312SRG	Silver	1M/ctn-19 lbs
10 x 4	4SRG	Silver	1M/ctn-22 lbs

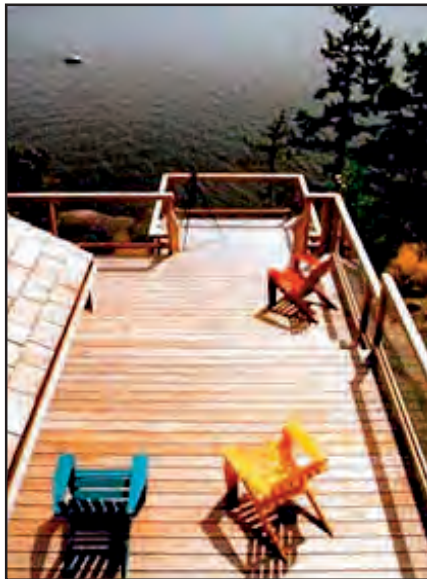

Applications

- Decks and patios
- Docks and gazebos
- Fences and lattice
- Outdoor furniture
- Siding and more
- Most outdoor projects



Rustguard™ – Phillips Head

Size	Part Number	Finish	Case QTY/WT
6 x 1-5/8	158RG	Silver	5M/ctn-23 lbs
8 x 2	2RG	Silver	3.5M/ctn-24 lbs
8 x 2-1/2	212RG	Silver	2.5M/ctn-28 lbs
9 x 3	3RG	Silver	2M/ctn-25 lbs
10 x 3-1/2	312RG	Silver	1M/ctn-19 lbs
10 x 4	4RG	Silver	750/ctn-17 lbs

Decking Screws

Our exclusive Rustguard® corrosion resistant coating provides maximum protection against rust and corrosion. They feature a self-drilling Type-17 point to eliminate splitting in most types of wood and man-made decking materials and self-countersinking nibs for a faster finished look. Rustguard® is a dull gray color that blends with most pressure treated lumber and many composite decking materials. It also helps prevent unsightly stains and streaks on decking materials. Made of case hardened 1022 carbon steel, they offer exceptional strength and unequalled holding power. They have been successfully tested to exceed 1800 hours salt spray resistance per ASTM B-117.

OK for ACQ™ and MCQ™ Decking.



Copperguard™ Screws			
Size	Part Number	Finish	Case QTY/WT
8 x 1-1/4	114CGTAN	Tan Magni	7.5M/ctn
8 x 1-5/8	158CGTAN	Tan Magni	5.5M/ctn
8 x 2	2CGTAN	Tan Magni	3.5M/ctn
8 x 2-1/2	212CGTAN	Tan Magni	2.5M/ctn
8 x 3	3CGTAN	Tan Magni	1.5M/ctn
8 x 3-1/2	312CGTAN	Tan Magni	1M/ctn

Ask about our 1lb, 3lb, 5lb, and Deck Pack™ packaged options.

- Copperguard™ organic polymer duplex coating system provides excellent corrosion protection in copper based pressure treated lumber.
- Flat head design with self countersinking nibs provides easy countersinking in a variety of wood and man made materials.
- Patented WoodMaster® cutter thread design eliminates splitting and easily slices through the hardest materials.
- Available in Tan and Redwood.
- Averaged 2000+ hours salt spray (tested in ACQ™ treated lumber)

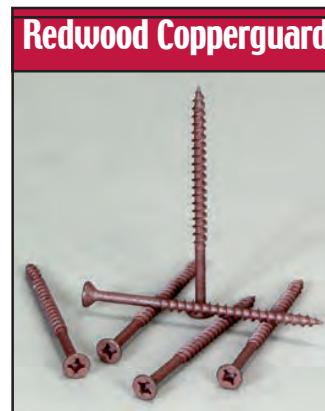
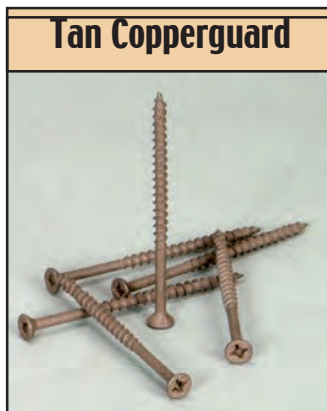

Our Copperguard™ deck screws have been continuously tested for over 18 months in ACQ™ treated wood in a variety of accelerated test environments in independent labs. Our organic polymer duplex coating system was one of the first products offered exclusively for copperbased pressure treated lumber like ACQ™. The WoodMaster® five-sided cutter thread design drives 39% faster and provides 19% greater holding power when compared to Type-17 points. Call our office today and request a complete test data report. Copperguard™ is available in tan and redwood to match practically any decking application.

Applications

- Decks and patios
- Fences and lattice
- Okay for ACQ™ lumber
- Docks and gazebos
- Outdoor furniture
- Most outdoor projects



Truss Head Screws for Cabinet Installation

Truss Screws



Truss Head Deep Thread & Half Thread-Phillips

Size	Part Number	Finish	Case QTY/WT
10 x 2-1/2	BTXP10212R3F	Black	2M/ctn-30 lbs
10 x 2-1/2	BTXP10212R3Z	Zinc	2M/ctn-30 lbs
10 x 3	BTXP10300R3Z	Zinc	1.5M/ctn-27 lbs

Plated Cabinet Installation Screws for Wood Studs.



Truss Head Fine Thread & Half Thread-Phillips Drill Point

Size	Part Number	Finish	Case QTY/WT
10 x 2-1/2	BTXF10212D3Z	Zinc	2M/ctn-31 lbs

Plated Cabinet Installation Screws for Metal Studs.
Drill Point for heavier gauge metal studs.



Truss Head Type 17 Point Deep Thread & Half Thread Recex®

Size	Part Number	Finish	Case QTY/WT
10 x 2-1/2	BTRP10212S2Z	Zinc	2M/ctn
10 x 3	BTRP10300S2Z	Zinc	1.5M/ctn

Deerwood's Truss Head Screws are the fasteners of choice for the professional cabinet installer. The large bearing surface of the head helps eliminate pull-through and allows the screw to be torqued to its maximum to insure a proper fit against the wall. We offer these installation screws in lengths up to 3". The #10 body offers maximum shear loads and pullout strength. These fasteners are offered with your choice of our classic deep thread design, or our self-drilling points for heavy duty steel studs. Deerwood is now pleased to offer these popular installation screws with a Recex® (Square/ Phillips) Drive for optimum drive torque and eliminating bit camout and Type 17 points.

Truss Head - Modified Truss Screws



Truss Head Type A Tapping Screw - Phillips

Size	Part Number	Finish	Case QTY/WT
8 x 1/2	BTXA08012R2Z	Zinc	16M/ctn-56 lbs
8 x 5/8	BTXA08058R2Z	Zinc	13.5/ ctn-51 lbs
8 x 7/16	BTXA08716R2Z	Zinc	14M/ctn-29 lbs

For attaching flat surface hardware to hardwoods.



Modified Truss Head Type A Tapping Screw - Phillips

Size	Part Number	Finish	Case QTY/WT
8 x 7/16	BMXA08716R2Z	Zinc	14M/ctn-38 lbs
8 x 7/16	MMXA08716R2Z	Zinc	1M/box-2.85 lbs
8 x 1/2	BMXA08012R2F	Black	16M/ctn-48 lbs
8 x 1/2	BMXA08012R2Z	Zinc	16M/ctn-48 lbs
8 x 1/2	MMXA08012R2Z	Zinc	1M/box-3 lbs
8 x 1/2	LMXA08012R2Z	Zinc	5M/box-14.49lbs

Commonly used with ball bearing drawer slides.
Large Washer Head Screws with 11/32" Head Diameter.



Modified Truss Deep Thread Type 17 - Phillips

Size	Part Number	Finish	Case QTY/WT
8 x 3/4	BMXP08034S2N	Nickel	8M/ctn-26 lbs
8 x 3/4	MMXP08034S2N	Nickel	1M/ctn

Commonly used to attach hardware parts to particleboard and softwoods.

Heat Treating - Proper heat treating is critical in insuring that a fastener functions properly in a given application. Deerwood's fasteners are manufactured to our own specifications and "torque" tested at our factory and again upon receipt in our warehouse.



Truss Head Deep Thread Screw - Phillips

Size	Part Number	Finish	Case QTY/WT
6 x 1/2	BTXP06012R2Z	Zinc	22M/ctn-42 lbs
6 x 1/2	MTXP06012R2Z	Zinc	1M/box-1.95 lbs
6 x 5/8	BTXP06058R2Z	Zinc	20M/ctn-44 lbs
8 x 1/2	BTXP08012R2Z	Zinc	16M/ctn-49 lbs
8 x 1	BTXP08100R2Z	Zinc	8M/ctn-38 lbs
8 x 1-1/8	BTXP08118R2Z	Zinc	7M/ctn-35 lbs
8 x 1-1/4	BTXP08114R2Z	Zinc	6M/ctn-33 lbs
8 x 1-1/2	BTXP08112R2Z	Zinc	5M/ctn-31 lbs

Larger Truss head reduces sinking of the head into softwoods.



Truss Recex® #2 Drive

Size	Part Number	Finish	Case QTY/WT
6 x 3/8	BTRP06038R2L	Lube	15M/ctn-30 lbs
6 x 1/2	BTRP06012R2L	Lube	15M/ctn-37 lbs
6 x 5/8	BTRP06058R2L	Lube	15M/ctn-39 lbs
6 x 1	BTRP06100R2L	Lube	10M/ctn-35 lbs
6 x 1-1/4	BTRP06114R2L	Lube	7.5M/ctn-31 lbs

Low profile head and large bearing surface where head height is important. Popular applications would be drawer slides, catches, hinges and back panels.

Our Modified Truss Head Screws offer maximum bearing surface to increase holding power. We have modified the head height to allow the screw to be used in tight spaces where head clearance is minimal. These features make our Modified Truss Head Screws the perfect choice for attaching metal drawer slides. The low profile head insures the head height of the fastener will not interfere with the operation of the rollers and track on most all makes of slides.



Drawer Front Adjusting Screws

Drawer Front Screws



Modified Truss-Phillips			
Size	Part Number	Finish	Case QTY/WT
8 x 7/8	BMXP08078S2Z	Zinc-full thrd	10M/ctn-54 lbs
8 x 1	MMXP08100S2Z	Zinc-1/2 thrd	1M/box-6 lbs
8 x 1-1/8	BMXP08118S2Z	Zinc-1/2 thrd	6.5M/ctn-44 lbs
8 x 1-1/8	MMXP08118S2Z	Zinc-1/2 thrd	1M/box-6.43 lbs
8 x 1-1/4	BMXP08114S2Z	Zinc-1/2 thrd	6.5M/ctn-46 lbs
8 x 1-1/4	MMXP08114S2Z	Zinc-1/2 thrd	1M/box-7.03 lbs
8 x 1-1/2	BMXP08112S2Z	Zinc-1/2 thrd	5M/ctn-40 lbs
8 x 1-1/2	MMXP08112S2Z	Zinc-1/2 thrd	1M/box-8 lbs

Deep Thread Extra-Large Washer Head Screws

Drawer Front Adjusting Screws Available in the following...

- Modified Truss-Phillips Deep Thread Type 17 Extra-Large Washer Head Screws
- Modified Truss-Recex® Deep Thread Type-17 Extra-Large Washer Head Screws



Modified Truss-Recex® Type 17			
Size	Part Number	Finish	Case QTY/WT
8 x 1	BMRP08100S2Z	Zinc 1/2 thrd	7M/ctn-43 lbs
8 x 1	MMRP08100S2Z	Zinc 1/2 thrd	1M/box-6 lbs
8 x 1-1/8	BMRP08118S2Z	Zinc 1/2 thrd	6.5M/ctn-42 lbs
8 x 1-1/8	MMRP08118S2Z	Zinc 1/2 thrd	1M/box-6.43 lbs
8 x 1-1/4	BMRP08114S2Z	Zinc 1/2 thrd	6.5M/ctn-47 lbs
8 x 1-1/4	MMRP08114S2Z	Zinc 1/2 thrd	1M/box-7.03 lbs

Deep Thread Type-17 Extra-Large Washer Head Screws

Our Drawer Front Adjusting Screws have an extra large washer built into the head for increased bearing surface and maximum hole coverage. The unique head design has been a timesaver for the professional cabinet maker for over eight years. Simply drill an oversized 5/16" hole in the drawer box. Attach the drawer front by driving the drawer front adjusting screw through the box into the drawer front. The oversized hole allows for adjustments to be made to the drawer front thus insuring perfect alignment. These small details complete the professional look of your installation quickly and effortlessly. We have a special thread length on our drawer front adjusting screw to insure the thread engagement is in the drawer front only. This insures a tight fit and eliminates loosening. Available in Phillips Drive and Recex® Drive with Type-17 Point.

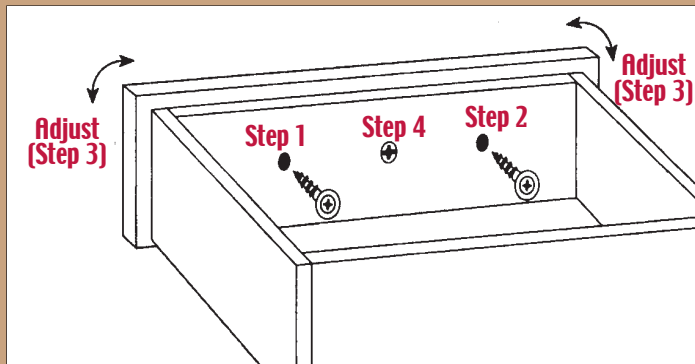

1. Drill oversize 5/16" hole in drawer box.
2. Attach drawer front.
3. Adjust drawer front.
4. Fix drawer front with knob or pull screws.



Oval Head Phillips Deep Thread Screws

Size	Part Number	Finish	Case QTY/WT
6 x 5/8	BOXP06058R2E	Ant. Eng.	30M/ctn-58 lbs
6 x 5/8	MOXP06058R2E	Ant. Eng.	1M/box-1.9 lbs
6 x 5/8	MOXP06058R2R	Brt. Brass	1M/box-1.9 lbs

- The Oval Head countersinks like a Flat Head Screw, but the head is slightly rounded to achieve that “finished” look.



Trim Head Screws

Size	Part Number	Finish	Case QTY/WT
6 x 1	BVSA06100R1F	Black-#1	12.5M/ctn-34 lbs
6 x 1-5/8	BVSA06158R1F	Black-#1	5M/ctn-23 lbs
6 x 1-5/8	MVSA06158R1F	Black-#1	1M/box-4.42 lbs
6 x 2-1/4	BVSA06214R1F	Black-#1	3M/ctn-17 lbs
6 x 2-1/4	MVSA06214R1F	Black-#1	1M/box-6.19 lbs

Small Head results in a smaller hole for wood filling and finishing

- Trim Head Screws available in Fine Thread-Robertson® and Square Recess Full Thread Sharp Point

Trim Heads are specially designed for applications in which the head of the screw needs to be as small as possible. Trim Heads resemble finishing nails in both appearance and function. The head of a #4 screw is used on a #6 screw, permitting the screw to countersink itself just like a finishing nail. The small head size allows it to be used to discreetly attach mouldings and trim to millwork, cabinetry and crafts. Our versatile thread design holds well in wood and also works well in light gauge steel studs. Trim Heads are available only in square (Robertson®) drive to insure optimum drivability and eliminate driver bit camout.



Firmit Connecting Screws



Firmit Connecting Screws

Size	Part Number	Finish	Case QTY/WT
5 x 40mm	BKFP05400H2Z	With Hole	4M/ctn-36 lbs
7 x 50mm	BKFP07500H3Z	With Hole	2M/ctn-41 lbs

Flat Head Pozi Drive - Zinc

Ready-To-Assemble (RTA) and Knock-Down (KD) furniture can now be assembled with ease. Our Connecting Screws come with or without a hole for a Snap-On cover cap. These screws come with a Type-B thread style to insure maximum thread engagement in a pre-drilled hole. The extruded shoulder under the head creates a tight fit to insure proper alignment by the assembler. Also available with A Point.

Firmit Connecting Screws are available in the following...

- Firmit Connecting Screws - Flat Head Pozi Drive/Zinc
- Firmit Connecting Screws - Flat Head Pozi Drive with Nibs Sharp Point Zinc, **with hole**
- Firmit Connecting Screws - Flat Head Pozi Drive with Nibs Sharp Point Zinc, **without hole**



Firmit Connecting Screws

Size	Part Number	Finish	Case QTY/WT
7 x 50mm	BKFP07500HNZ	Zinc	2.5M/ctn-50 lbs

Flat Head Pozi Drive with Nibs Sharp Point Zinc - with Hole



Firmit Connecting Screws

Size	Part Number	Finish	Case QTY/WT
7 x 50mm	BKFP07500RNZ	Zinc	2.0M/ctn-40 lbs

Flat Head Pozi Drive with Nibs Sharp Point Zinc - without Hole

Special Long-stem cap cover holds firmly in screws with drilled heads.

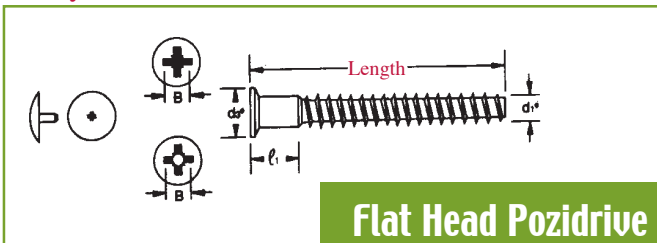

For Knock-Down (KD) or Ready-To-Assemble (RTA) applications.

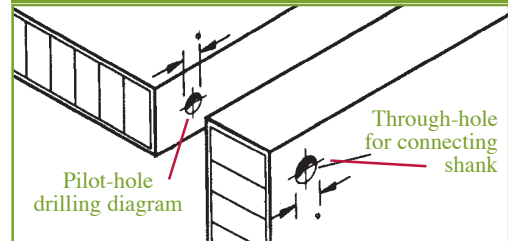

For "extra firm" standard cabinet or furniture construction.



Truss Head Machine Screws – Phillips/Slot Recess

Size	Part Number	Finish	Case QTY/WT
8-32 x 1/2	MTCM0832012Z	Zinc	1M/box-3.8 lbs
8-32 x 5/8	BTCM0832058Z	Zinc	12M/ctn-53 lbs
8-32 x 3/4	BTCM0832034Z	Zinc	10M/ctn-51 lbs
8-32 x 7/8	BTCM0832078Z	Zinc	8.5M/ctn-47 lbs
8-32 x 7/8	MTCM0832078Z	Zinc	1M/box-5.53 lbs
8-32 x 1	BTCM0832100Z	Zinc	7.5M/ctn-46 lbs
8-32 x 1	CTCM0832100Z	Zinc	100pc-.63 lbs
8-32 x 1	MTCM0832100Z	Zinc	1M/box-6.3 lbs
8-32 x 1-1/8	BTCM0832118Z	Zinc	6.5M/ctn-43 lbs
8-32 x 1-1/8	MTCM0832118Z	Zinc	1M/box-6.62 lbs
8-32 x 1-1/4	BTCM0832114Z	Zinc	5.5M/ctn-40 lbs
8-32 x 1-1/4	CTCM0832114Z	Zinc	100pc-.7 lbs
8-32 x 1-1/4	MTCM0832114Z	Zinc	1M/box-7 lbs
8-32 x 1-3/8	BTCM0832138Z	Zinc	5M/ctn-38 lbs
8-32 x 1-3/8	MTCM0832138Z	Zinc	1M/box-7.87 lbs
8-32 x 1-1/2	BTCM0832112Z	Zinc	4.5M/ctn-38 lbs
8-32 x 1-1/2	CTCM0832112Z	Zinc	100pc-.84 lbs
8-32 x 1-1/2	MTCM0832112Z	Zinc	1M/box-8.4 lbs
8-32 x 1-5/8	BTCM0832158Z	Zinc	4M/ctn-36 lbs
8-32 x 1-5/8	CTCM0832158Z	Zinc	100pc-.93 lbs
8-32 x 1-5/8	MTCM0832158Z	Zinc	1M/box-9.25 lbs
8-32 x 1-3/4	BTCM0832134Z	Zinc	4M/ctn-38 lbs
8-32 x 1-3/4	CTCM0832134Z	Zinc	100pc-.93 lbs
8-32 x 1-3/4	MTCM0832134Z	Zinc	1M/box-9.27 lbs
8-32 x 2	BTCM0832200Z	Zinc	3.5M/ctn-37 lbs
8-32 x 2	MTCM0832200Z	Zinc	1M/box-10.6 lbs

Machine Screws are available in the following...

- Truss Head Machine Screws - Phillips/Slot Recess
- Standard 8-32 Thread
- Truss Head Break-Away Standard 8-32 Machine Screws, Phillips/Slot Recess: Breaks at 3/4, 1, 1-1/4 and 1-1/2 inch.

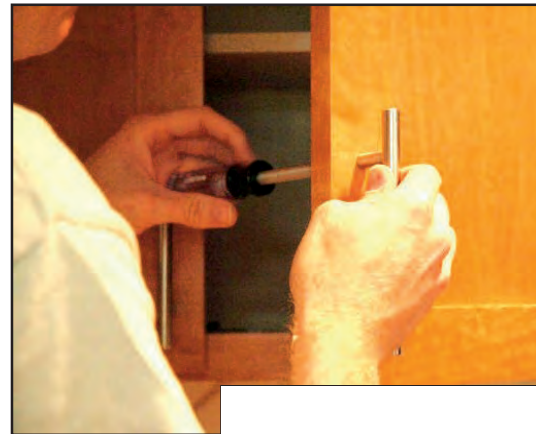

Truss Head Break-Away Standard 8-32 MachineScrews

Size	Part Number	Finish	Case QTY/WT
8-32 x 1-3/4	BTCB0832134Z	Zinc	4M/ctn-35 lbs
8-32 x 1-3/4	CTCB0832134Z	Zinc	100pc-.93 lbs
8-32 x 1-3/4	MTCB0832134Z	Zinc	1M/box-9.27 lbs

Phillips and Slot Recess



Truss Head Break-Away M4 Metric Machine Screws

Size	Part Number	Finish	Case QTY/WT
M4 x 45mm	BTCBM4X4500Z	Zinc	4M/ctn-36 lbs
M4 x 45mm	MTCBM4X4500Z	Zinc	1M/ctn-9 lbs

Phillips and Slot Recess

Every professional cabinet maker should have a supply of these screws. Inevitably you are in the middle of finishing that last detail and find out you do not have the correct size machine screw for mounting the hardware. Our breakaways are notched in 1/4" increments to allow easy breaking of the unneeded length and insures you have the correct length everytime.



Pan Head Screws



Pan Head Deep Thread Screws – Phillips

Size	Part Number	Finish	Case QTY/WT
6 x 3/8	BPXP06038R2Z	Zinc	30M/ctn-47 lbs
6 x 7/16	BPXP06716R2Z	Zinc	30M/ctn-55 lbs
6 x 7/16	MPXP06717R2Z	Zinc	1M/box-1.83 lbs
6 x 1/2	BPXP06012R2E	Ant. Eng.	30M/ctn-55 lbs
6 x 1/2	BPXP06012R2Z	Zinc	30M/ctn-54 lbs
6 x 1/2	MPXP06012R2Z	Zinc	1M/box-1.88 lbs
6 x 5/8	BPXP06058R2E	Ant. Eng.	25M/ctn-56 lbs
6 x 5/8	MPXP06058R2E	Ant. Eng.	1M/ctn-2.24 lbs
6 x 5/8	BPXP06058R2Z	Zinc	25M/ctn-56 lbs
6 x 5/8	MPXP06058R2Z	Zinc	1M/box-2.25 lbs
6 x 3/4	BPXP06034R2Z	Zinc	18M/ctn-45 lbs
8 x 7/16	BPXP08716R2Z	Zinc	22M/ctn-58 lbs
8 x 1/2	BPXP08012R2Z	Zinc	20M/ctn-54 lbs
8 x 1/2	MPXP08012R2Z	Zinc	1M/box-2.8 lbs
8 x 5/8	BPXP08058R2F	Black	15M/ctn-50 lbs
8 x 5/8	BPXP08058R2Z	Zinc	15M/ctn-50 lbs
8 x 5/8	MPXP08058R2Z	Zinc	1M/box-3.2 lbs
8 x 3/4	BPXP08034R2F	Black	10.5M/ctn-38lbs
8 x 3/4	BPXP08034R2Z	Zinc	10.5M/ctn-38lbs
8 x 3/4	MPXP08034R2Z	Zinc	1M/box-3.62 lbs
8 x 1	BPXP08100R2F	Black	9M/ctn-39 lbs
8 x 1	BPXP08100R2Z	Zinc	9M/ctn-39 lbs
8 x 1-1/8	BPXP08118R2Z	Zinc	8M/ctn-38 lbs
8 x 1-1/4	BPXP08114R2F	Black	7M/ctn-36 lbs
8 x 1-1/4	BPXP08114R2Z	Zinc	7M/ctn-36 lbs
8 x 1-1/2	BPXP08112R2F	Black	6M/ctn-37 lbs
8 x 1-1/2	BPXP08112R2Z	Zinc	6M/ctn-37 lbs
10 x 1/2	BPXP10012R2Z	Zinc	11M/ctn-49 lbs
10 x 5/8	BPXP10058R2F	Black	10M/ctn-50 lbs
10 x 5/8	BPXP10058R2N	Nickel	10M/ctn-50 lbs
10 x 5/8	MPXP10058R2N	Nickel	1M/box-4.86 lbs
10 x 3/4	BPXP10034R2F	Black	9M/ctn-47 lbs
10 x 3/4	BPXP10034R2N	Nickel	9M/ctn-47 lbs
10 x 3/4	CPXP10034R2N	Nickel	100pc-.54 lbs
10 x 3/4	MPXP10034R2N	Nickel	1M/box-.54 lbs
10 x 1	BPXP10100R2F	Black	7M/ctn-42 lbs
10 x 1	BPXP10100R2N	Nickel	7M/ctn-42 lbs



Pan Head Type A Tapping Screws – Phillips

Size	Part Number	Finish	Case QTY/WT
6 x 3/8	BPXA06038R2Z	Zinc	30M/ctn-54 lbs
6 x 1/2	BPXA06012R2Z	Zinc	30M/ctn-63 lbs

For attaching flat surface hardware parts to hardwoods.
Higher head profile than Truss Heads.

A wide variety of Pan Head Wood & Tapping Screws are available. The Pan Head design offers a right angle under the head to allow flat surface hardware and brackets to be attached firmly and securely. The Pan Head also allows for adjustment when positioning hardware. Some of our Pan Head screws come with a Type-17 point to eliminate splitting & the need for pre-drilling.

Pan Head Screws Available in the following...

- Pan Head Deep Thread Screws Phillips Recess
- Pan Head Type A Tapping Screws Phillips Recess
- Pan Head Type A Tapping Screws No. 2 Robertson®, Square Recess
- Pan Head Type Deep Thread Screws No. 2 Robertson®, Square Recess
- Pan Head Chipboard Screws Type 17 Phillips Recess



Pan Head Deep Thread Screws – Robertson®

Size	Part Number	Finish	Case QTY/WT
8 x 3/4	BPSP08034R2F	Black	10.5M/ctn-36lbs
8 x 1-1/4	BPSP08114R2Z	Zinc	7M/ctn-36 lbs
10 x 1-1/2	BPSP10112R2F	Black	4M/ctn-34 lbs
10 x 1-3/4	BPSP10134R2F	Black	3M/ctn-29 lbs

No. 2 Robertson®, for attaching small hardware parts to particleboard and softwoods.



Pan Head Chipboard Type 17 Screws – Phillips

Size	Part Number	Finish	Case QTY/WT
8 x 3/4	BPXC08034SZ	Zinc	10.5M/ctn-38lbs

For attaching small hardware parts to particleboard & softwoods.



Pan Head Recex® Deep Thread Screw

Size	Part Number	Finish	Case QTY/WT
6 x 1/2	BPRP06012R1L	Lube	15M/ctn-29 lbs
6 x 5/8	BPRP06058R1L	Lube	15M/ctn-32 lbs
8 x 5/8	BPRP08058R2L	Lube	12M/ctn-42 lbs
8 x 3/4	BPRP08034R2L	Lube	10M/ctn-38 lbs
10 x 5/8	BPRP10058R2L	Lube	8M/ctn-40 lbs



For attaching small hardware parts to particleboard & softwoods.



Face Frame Pocket Screws

Deerwood Fasteners International knows face framing! We carry a comprehensive line of face frame and pocket hole screws. Our variety of head styles, drive styles, thread styles, diameters and recesses provides you with the perfect screw for your application - whatever the application may be!

A Complete Line of High Quality Face Frame - Pocket Hole Screws!

THREAD STYLES	DRIVE STYLES	HEAD STYLES	POINTS
 <p>Fine Thread: provides easy driving and maximum strength in hardwoods.</p>	 <p>Phillips Recess Drive: an old standard improved with a deeper recess to prevent bit slip.</p>	 <p>Pan Head: the "original" but with a higher head height to insure proper bit fit.</p>	 <p>Type 17 for maximum pre-drill power.</p>
 <p>Deep Thread: offers easy driving & maximum hold in softwoods and man-made materials.</p>	 <p>Recex® Drive Square Phillips: made better by increasing drive depth for max. grip.</p>	 <p>Round Washer Head: with a larger head diameter to prevent "sinking".</p>	
 <p>Hi-Lo™ Thread: designed to be the perfect solution for all applications.</p>	 <p>Square Recess Drive: fits square bits but with a deeper recess for better grip.</p>	 <p>Fillister Flat Top Pan Head: maximum driver bit engagement insures "slip-proof" driving, no camouts.</p>	

Face Frame

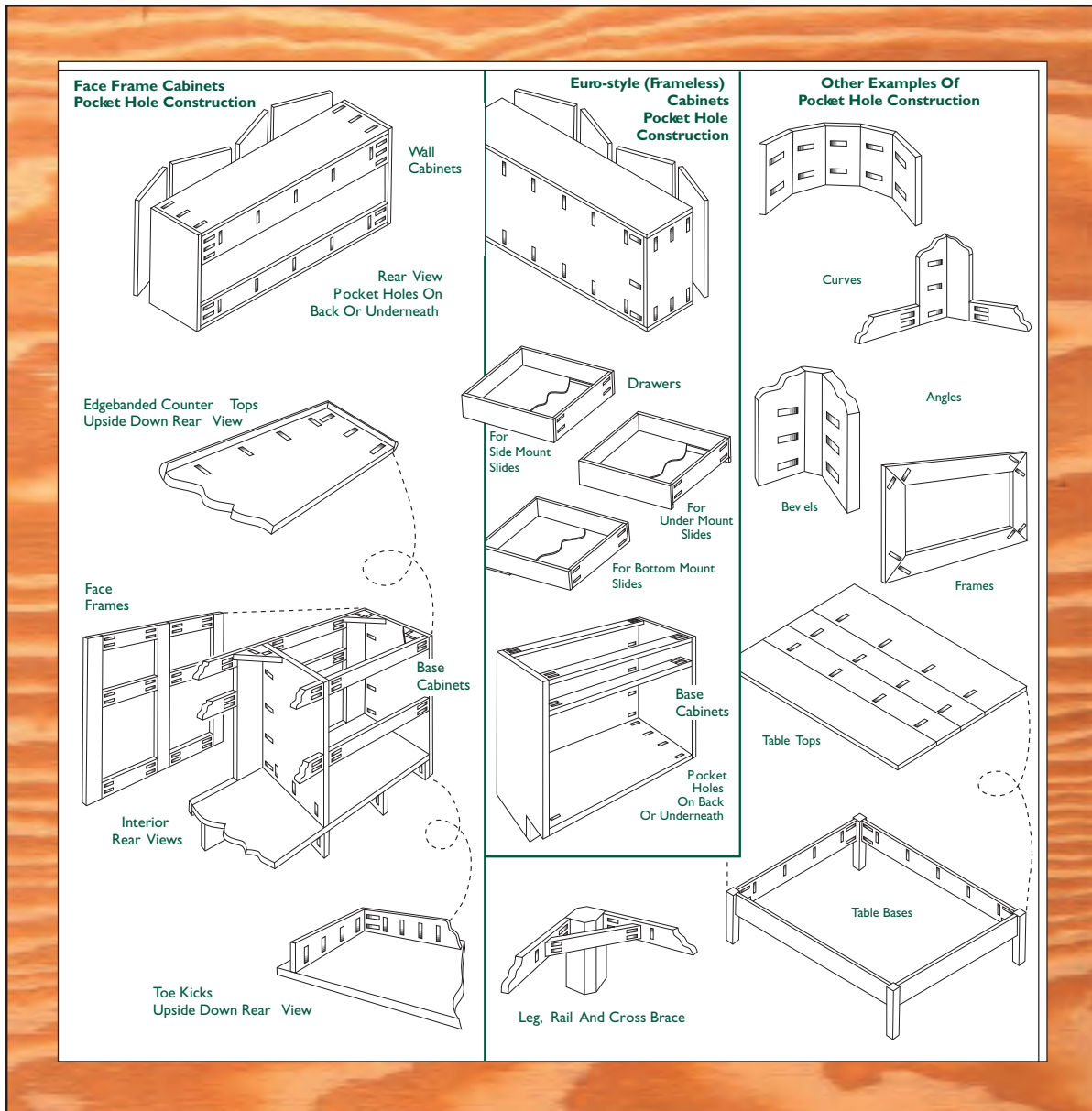

Face Frame Pocket Screws



Pan Head Square Drive Fine Thread Type 17

Size	Part Number	Finish	Case QTY/WT
6 x 1-1/4	BPSA06114S2F	Black	7.5M/ctn-32 lbs
6 x 1-1/4	MPSA06114S2F	Black	1M/box-4 lbs
6 x 1-1/2	BPSA06112S2F	Black	6M/ctn-30 lbs
6 x 1-1/2	MPSA06112S2F	Black	1M/box-5 lbs

Square Recess Drive insures slip-proof driving, no camouts.

Flat Head Face Frame Screws Available in the following...

- Pan Head in Phillips and Square Recess with Fine Thread Type 17 Point
- Pan Head Square Recess with Deep Thread Type 17 Point
- Flat Top Pan Square Hi-Lo Type 17
- Round Washer Head Recex® with Deep Thread Type 17 Point



Pan Head Phillips Drive Fine Thread Type 17

Size	Part Number	Finish	Case QTY/WT
6 x 1-1/4	BPXA06114S2F	Black	10M/ctn-40 lbs
6 x 1-1/2	BPXA06112S2F	Black	8.5M/ctn-35 lbs



Round Washer Head Recex® Deep Thread Type 17

Size	Part Number	Finish	Case QTY/WT
8 x 1-1/4	BWRP08114F2F	Black	7M/ctn-43 lbs
8 x 1-1/2	BWRP08112F2F	Black	5M/ctn- 31 lbs

Larger body for added strength.



Pan Head Square Deep Thread Type 17

Size	Part Number	Finish	Case QTY/WT
7 x 1-1/4	BPSP07114S2F	Black	9M/ctn-39 lbs
7 x 1-1/4	MPSP07114S2F	Black	1M/box-4.22 lbs
7 x 1-1/2	BPSP07112S2F	Black	6M/ctn-30 lbs
7 x 1-1/2	MPSP07112S2F	Black	1M/box-5 lbs



Flat Top Pan Head Square Pocketmaster® Deep Thread XL Type 17

Size	Part Number	Finish	Case QTY/WT
7 x 1-1/4	BLSP07114X2L	Lube	7.5M/ctn-37 lbs
7 x 1-1/4	MLSP07114X2L	Lube	1M/box-5 lbs
7 x 1-1/2	BLSP07112X2L	Lube	6M/ctn-34 lbs
7 x 1-1/2	MLSP07112X2L	Lube	1M/box-5.7 lbs



Fillister Head Square Hi-Lo" Thread Type 17

Size	Part Number	Finish	Case QTY/WT
7 x 1-1/4	BLSH07114S2L	Lube	7.5M/ctn-37 lbs
7 x 1-1/4	MLSH07114S2L	Lube	1M/box-5 lbs
7 x 1-1/2	BLSH07112S2L	Lube	6M/ctn-34 lbs
7 x 1-1/2	MLSH07112S2L	Lube	1M/box-5.7 lbs



Flat Top Pan Robertson® Square Fine Thread Type

Size	Part Number	Finish	Case QTY/WT
7 x 1-1/4	BLSA07114S2L	Lube	7.5M/ctn-37 lbs
7 x 1-1/4	MLSA07114S2L	Lube	1M/box-5 lbs
7 x 1-1/2	BLSA07112S2L	Lube	6M/ctn-35 lbs

Face Frame



Painted Head Screws



Painted Truss Head Deep Thread & Half Thread – Phillips

Size	Part Number	Finish	Case QTY/WT
10 x 2-1/2	BTXP10212R3C	White	1.5M/ctn-27 lbs
10 x 2-1/2	BTXP10212R3D	Sand	1.5M/ctn-27 lbs
10 x 3	BTXP10300R3C	White	1M/ctn-22 lbs
10 x 3	BTXP10300R3D	Sand	1M/ctn-22 lbs

Painted cabinet installation screws for Wood Studs.



Painted Truss Head Deep Thread & Half Thread – Recex® Type 17

Size	Part Number	Finish	Case QTY/WT
10 x 2-1/2	BTRP10212S2C	White	2M/ctn
10 x 3	BTRP10300S2C	White	1.5M/ctn
10 x 3	BTRP10300S2D	Sand	1.5M/ctn



Painted Truss Head Fine Thread, Drill Point– Phillips

Size	Part Number	Finish	Case QTY/WT
10 x 2-1/2	BTXF10212D3C	White	1.5M/ctn-27 lbs
10 x 2-1/2	BTXF10212D3D	Sand	1.5M/ctn-27 lbs

Painted cabinet installation screws for Metal Studs.
Drill Point – For Heavier gauge Metal Studs.

Our Painted Head Screws are specially coated to give you a professional finished look without the added expense associated with matching cover caps. Our screws are zinc plated prior to painting to insure optimum adhesion of the paint to the head. This procedure practically eliminates chipping and scratching of the paint to keep the fresh look. Deerwood offers these specialty fasteners in sizes and styles that accommodate most any applications.



Flat Head Pozi Drive Euro Screws			
Size	Part Number	Finish	Case QTY/WT
5 x 10mm	BFPE05100R2N	Nickel	15M/ctn-46 lbs
5 x 10mm	MFPE05100R2N	Nickel	1M/box-3 lbs
5 x 10mm	LFPE05100R2N	Nickel	5M/box-15 lbs
5 x 11.5mm	BFPE05115R2N	Nickel	12M/ctn-42 lbs
5 x 11.5mm	MFPE05115R2N	Nickel	1M/box-4 lbs
5 x 13mm	BFPE05130R2N	Nickel	10M/ctn-40 lbs
5 x 13mm	MFPE05130R2N	Nickel	1M/box-4 lbs
5 x 13mm	LFPE05130R2N	Nickel	5M/box-20 lbs
5 x 14.5mm	BFPE05145R2N	Nickel	10M/ctn-46 lbs
5 x 14.5mm	MFPE05145R2N	Nickel	1M/box-5 lbs
5 x 20mm	BFPE05200R2N	Nickel	8M/ctn-50- lbs
5 x 25mm	MFPE05250R2N	Nickel	1M/box-8 lbs

7.2mm Head Diameter for 5mm holes Blum® compatible

- Flat Head Pozi Drive Screws
- Flat Head Phillips Euro Screws

*Commonly used for drawer slides in European style cabinets.



Flat Head Phillips Drive Euro Screws			
Size	Part Number	Finish	Case QTY/WT
5 x 13mm	BFXE05130R2N	Nickel	10M/ctn-41 lbs
5 x 13mm	DFXE05130R2N	Nickel	500pc/box-2 lbs

**7.5mm Head Diameter for 5mm holes
Grass® compatible - Case Hardened**



Our Euro Screws are available in a nickel finish that perfectly matches the “European” hardware used on your project. These small screws have a Blunt Type B point that allows them to have maximum holding power in a pre-drilled hole. The aggressive deep thread design insures maximum holding power in MDF and Particle board as well as hardwoods.



If you are using automatic insertion machinery, we can laser sort this product to eliminate down time and increase production.

Fastener Kits

SAMPLEKIT-03



Hinge / Hardware Fastener Kit SAMPLEKIT-03

The Hinge/hardware Kit contains the most popular items for installation of hinges and other types of decorative and functional hardware. It includes 4 lengths of machine screws as well as 8-32 and metric breakaway screws for decorative knobs and pulls. It also includes fasteners most commonly used for attaching epoxy drawer slides, concealed hinges, piano hinges, ball bearing drawer slides and surface mounted hinges. General application information for each item is shown on the inside kit label.

SAMPLEKIT-04



Wood Shop Fastener Kit SAMPLEKIT-04

Designed for general shop use, the Wood Shop Kit contains the most commonly used woodworking fasteners as well as specialty fasteners such as Drawer Front Adjuster screws and Trim Head screws. It also contains 3 types of Installation screws, 2 finishing cup washers, square and phillips cover caps. General application information for each item is shown on the inside kit label.

SAMPLEKIT-05



Cabinet Installation Fastener Kit SAMPLEKIT-05

The Cabinet Installation Kit contains fasteners which are used primarily to attach cabinets to various types of material. Included are Drill Point and Needle Point fasteners for metal applications as well as Truss head and Flat head fasteners in 2-1/2" and 3" lengths. Drive bits (4) for each of the various recesses are included in the kit. General application information for each item is shown on the inside kit label.

SAMPLEKIT-06



Face Frame Fastener Kit SAMPLEKIT-06

The Face Frame Fastener Kit contains fasteners which are used primarily to assemble kitchen cabinet face frames but can be used in various other applications: Drawer Boxes, Toe-Kicks, Counter Edges, Splashes, Scribes, Mouldings, etc. Three different head styles.

Woodmaster Jar Program

Woodmaster Jar Program



■ Now a point of purchase display for your store, with the most popular size selection. All jars sell for the same price and include a FREE Driver Bit.

Woodmaster Jar Program			
Size	Part Number	Finish	Case QTY/WT
8 x 1-1/4	JFRW08114R2L-500	Lube	8Jars/ctn-19 lbs
8 x 1-1/2	JFRW08112R2L-500	Lube	8Jars/ctn-22 lbs
8 x 2	JFRW08200R2L-250	Lube	8Jars/ctn-15 lbs
8 x 2-1/2	JFRW08212R2L-250	Lube	8Jars/ctn-18 lbs
8 x 1-1/4	JWRW08114R2L-500	Lube	8Jars/ctn-24 lbs
8 x 1-1/2	JWRW08112R2L-500	Lube	8Jars/ctn-26 lbs
8 x 3	JWRW08300R2L-125	Lube	8Jars/ctn-13 lbs
7 x 1-1/4	JLSP07114X2L-500	Lube	8Jars/ctn-21 lbs
7 x 1-1/2	JLSP07112X2L-500	Lube	8Jars/ctn-27 lbs

Accessories



1/4 Hex Double Power Drivers

Size	Part Number	Recess Size / Type
2 x 2-1/2"	TBS200X212DD	No. 2 - Square Drive
2 x 3-1/2"	TBS200X312DD	No. 2 - Square Drive
2 x 2-1/2"	TBX200X212WD	No. 2 - Phillips Drive
2 x 3-1/2"	TBX200X312WD	No. 2 - Phillips Drive

Phillips and Square available with drivers on both ends.



Robertson® / Recex® Driver Bits

Size	Part Number	Recess Size / Type
1 x 1	7200144110050007	No. 1-Square Drive
1 x 2	7200144000510007	No. 1-Square Drive
1 x 3	7200144000810007	No. 1-Square Drive
1 x 4	7200144001010007	No. 1-Square Drive
1 x 6	7200144001410007	No. 1-Square Drive
2 x 1	7200144110060007	No. 2-Square Drive
2 x 2	7200144000520007	No. 2-Square Drive
2 x 3	7200144000820007	No. 2-Square Drive
2 x 4	7200144001020007	No. 2-Square Drive
2 x 6	7200144001420007	No. 2-Square Drive
2 x 1	7200164110060407	No. 2-Square Undersized
2 x 2	7200164000520407	No. 2-Square Undersized
2 x 3	7200164000820407	No. 2-Square Undersized
2 x 4	7200164001020407	No. 2-Square Undersized
2 x 6	7200164004120407	No. 2-Square Undersized
3 x 1	7200144110070007	No. 3-Square Drive
3 x 2	7200144000530007	No. 3-Square Drive
3 x 3	7200144000830007	No. 3-Square Drive
3 x 4	7200144001030007	No. 3-Square Drive
3 x 6	7200144001430007	No. 3-Square Drive



Magnetic Bit Holder For 1 Inch Inserts

Size	Part Number
3 inches long	TH MAGBITHTS



Double End Bits, High Quality Steel, Plain Steel

Size	Part Number	Recess Size / Type
2 x 2"	TBC2PHX2SQDD	Phillips / Square

No.2 Recess with this Driver.



1/4 Hex Single Power Drivers & Insert Bits Square

Size	Part Number	Recess Size / Type
1 x 1 Insert	TBS100X100TS	No. 1 - Square Drive
2 x 1 Insert	TBS200X100TS	No. 2 - Square Drive
2 x 2"	TBS200X200TS	No. 2 - Square Drive
2 x 2-3/4"	TBS200X234TS	No. 2 - Square Drive
2 x 4-1/2"	TBS200X412TS	No. 2 - Square Drive
2 x 6"	TBS200X600TS	No. 2 - Square Drive



1/4 Hex Single Power Drivers & Insert Bits Phillips

Size	Part Number	Recess Size / Type
1 x 1 Insert	TBX100X100WS	No. 1 - Phillips Drive
2 x 1 Insert	TBX200X100WS	No. 2 - Phillips Drive
2 x 2"	TBX200X200WS	No. 2 - Phillips Drive
2 x 2-3/4"	TBX200X234WS	No. 2 - Phillips Drive
2 x 4-1/2"	TBX200X412WS	No. 2 - Phillips Drive
2 x 6"	TBX200X600WS	No. 2 - Phillips Drive
3 x 2"	TBX300X200WS	No. 3 - Phillips Drive



1/4 Hex Single Power Drivers & Insert Bits Square

Size	Part Number	Recess Size / Type
2 x 1 Insert	TBS200X100TS	No. 2 - Square Drive
2 x 2 Insert	TBS200X200TS	No. 2 - Square Drive
2 x 2-3/4 Insert	TBS200X234TS	No. 2 - Square Drive
2 x 4-1/2 Insert	TBS200X412TS	No. 2 - Square Drive
2 x 6 Insert	TBS200X600TS	No. 2 - Square Drive



Quick Release Magnetic Bit Holder

Size	Part Number
2-1/4 inches long	TH MAGBITDBL

For Single and Double End Bits

Accessories

Accessories



Hand Driver/Screwdrivers

Size	Part Number	Qty.
#1 x 3"	7200143000810438	10 per box
#1 x 7-1/2"	7200143201710438	10 per box
#1 x 10"	7200143302110438	10 per box
#2 x 3"	7200143000820438	10 per box
#2 x 7-1/2"	7200143201720438	10 per box
#2 x 10"	7200143302120438	10 per box
#3 x 7-1/2"	7200143201730438	10 per box
#3 x 10"	7200143302130438	10 per box

Customer logo can be placed on handle.



Multi-Bit Hand Driver

Size	Description
DWMULBITDRIV	Multi-Bit Hand Driver -6 bits



Finishing Cup Washers

Size	Part Number	Finish	Case QTY/WT
No. 8	MCUPN8XXXXXF	Black	1M/box-1.28 lbs
No. 8	LCUPN8XXXXXF	Black	5M/box-6.4 lbs
No. 8	MCUPN8XXXXXN	Nickel	1M/box-1.28 lbs
No. 8	LCUPN8XXXXXN	Nickel	5M/box-6.41 lbs
No. 8	MCUPN8XXXXXZ	Zinc	1M/box-1.28 lbs
No. 8	LCUPN8XXXXXZ	Zinc	5M/box-6.4 lbs

No. 8 - For #6 and #7 head screws

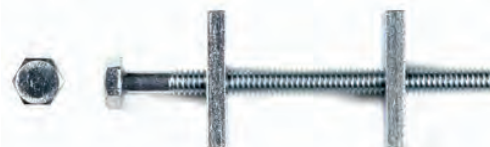

Hex Head Draw Bolts Zinc - 1/4-20 x 3-1/2

Size	Part Number	Finish	Case QTY/WT
1/4-20 x 3-1/2	VD1/4-20 x 3-1/2	Zinc	.5M/ctn-46 lbs
1/4-20 x 4	VD1/4-20X4	Zinc	.5M/ctn-49 lbs











Zip Bolt

Size	Part Number	Description
3 1/2	ZIPBOLT	60 pc/box-6 boxes/ctn=360pc/ctn w/6 bits
4MMx50MM	TBH4MMX50MMWS	4MM x 50MM Zipbolt Hex Bit

Wood Fastener Guide

Types of Screw Heads

-  **Flat Head** - Flat top surface with a countersunk bearing surface
-  **Pan Head** - Flat bearing surface, a semi-elliptical top surface, and cylindrical side surface.
-  **Truss Head** - Low profile semi-elliptical top surface with flat bearing surface.
-  **Oval Head** - Slightly rounded top surface with a countersunk bearing surface.
-  **Round Washer Head** - Built-in washer provides a larger bearing surface.
-  **Fillister Flat Top Pan Head** - Flat top pan head design allows for a deeper recess and optimum bit engagement.
-  **Modified Truss Head** - Low head profile, larger load bearing surface.
-  **Undercut** - Head designed to seat properly in undersized countersink holes.



Types of Screw Recesses

-  **Phillips** - Most common recess used in woodworking.
-  **Phillips-Slot** - Available with standard and metric machine screws.
-  **Robertson® Square** - Increasing in popularity due to more positive holding while driving.
-  **Recex®** - Square Phillips combination drive allows positive driving and after market serviceability.
-  **Pozidrive** - Available with Euro screws.





Recess Size – Phillips Drive



-  ← **No. 1**
-  ← **No. 2**
-  ← **No. 3**

Recess Size – Square Drive

-  ← **No. 1**
-  ← **No. 2**
-  ← **No. 3**

Major Thread & Head Diameter (Gage)

Approximate size for twinfast and depthread flat head screws from Deerwood Fasteners.



Wood Fastener Guide

- MEASUREMENTS -



Types of Screw Threads



Deep Thread - Single lead with a wider, deeper thread for use in soft woods and man-made boards.



WoodMaster™ Thread - Patented serrated tooth thread provides easy driving and greater holding power than type 17 points while reducing wood splitting.



Twinfast Thread - Double lead thread for use in hardwoods and tough applications.



Tapping Type A Screw Thread - Standard single lead thread and commonly used with pan, oval, truss and short length flat heads.



Machine Screws - Standard and metric thread for knobs, pull and metal parts.



Hi-Lo Thread - Greater holding power for hard and soft woods.

Types of Screw Points



Sharp Point - Available with twinfast and deep thread screws (30-35 degrees).



Type A Point - A gimlet point and normally available with tapping screws.



Type-17 Point - A special sharp fluted point to enhance wood penetration.



Type B Point - A blunt point available with machine, euro and firmit screws.

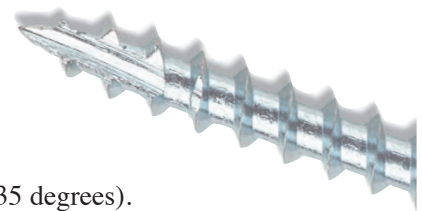

Catalog Guide – Part Number Explanation

B F X P O 8 I I 4 R 2 Z
1 2 3 4 { 5 } 6 7 8

Position #	Description	Examples
1	Package Code	B = Bulk M = 1,000 pc pack P = Poly-bagged C = 100 pc pack L = 5,000 pc pack D = 500 pc pack
2	Head Description	F = Flat Head L = Flat Top Pan Head P = Pan Head T = Truss Head RW = Raised Washer Head W = Round Washer O = Oval Head V = Trim Head H = Hex Head M = Modified Truss
3	Recess Type	X = Phillips P = Pozi R = Recex [®] S = Robertson [®] Square C = Combination (Slot and Phillips)
4	Thread Type	P = Deep Thread B = Breakaway E = Euro Screw T = Type F W = WoodMaster F = Fine Thread M = Machine Screw H = HiLo **A = Twinfast, Type A Tapping C = Chipboard
5	Gauge & Size	Example: 08114 = #8 x 1-1/4" 10300 = #10 x 3"
6	Variations	R = Regular N = Nibs H = Hole (for Cover Cap) U = Undercut S = Type 17 D = Drill Point X = XL Type 17
7	Recess Size	1 = #1 2 = #2 3 = #3
8	Finish Code	E = Antique English F = Black N = Nickel Y = Yellow Zinc D = Sand/Tan J = Stainless R = Bright Brass Z = Zinc S = Stat. Bronze C = White L = Lube (Lubricized [®]) A = Redwood

*Applies to most, but not all items.

**In general, screws under one inch are Tapping Screws; one inch and over are Twinfast.



Factory Tour



Step by Step

Manufacturers of quality fasteners since 1908

1.



We begin the manufacturing process with high quality carbon steel or stainless steel wire.

2.



Each Coil of wire is traced by lot number to insure quality from start to finish.

3.



The wire coils are fed into a heading machine that forms the head style, recess and cuts the headed blank to the proper length.



4.



The unhardened carbon steel or stainless steel wire is fed through the header machine and the wire is forced, using multiple blows, into heading dies that form the head style and recess.

Working to the highest standards to insure our consumers a quality product.

5.



Headers are lined up together so one operator can manage several machines at once. Operators continually check head dimensions, recess depth, blank length, etc. and compare these measurements to the drawing specifications to insure the fasteners are within specification.

6.



The headed blanks are fed from an overhead tote into a feeder bowl that supplies the threading machines.

7.



Now we thread the headed blanks. Headed blanks are fed through a vibrating hopper and down a feeder rail to line them up to be threaded.



8.



The hoses shown are to ventilate the smoke and cooling oil fumes out of the factory to provide a safer working environment.

9.

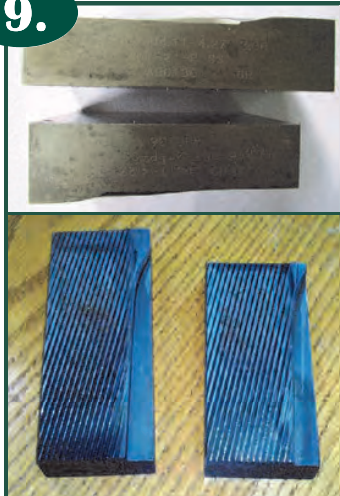

Threading dies are made to our exacting specifications. Each one is a matching set.

10.



The headed blanks are fed down a feeder rail and lined up to accept the threading dies. One threading die remains stationary while the other is pushed forward by the machine to roll the thread onto the headed blank and form the point of the screw.

11.



The threaded and headed parts are now fed into a tote and are ready to be sent to heat treat. The only other operation that may be needed now is to send these unhardened parts to the shank slot machine to have a Type-17 cutter point cut into them.

12.



After heat treating many of our screws are plated with a decorative plating or plated with yellow zinc dichromate and then coated with a special coating process that provides excellent corrosion resistant properties.

13.



Our quality control department constantly tests the fasteners for drive torque, breaking torque, driver bit fit, bend and yield, salt spray hours, etc. to insure our customers receive the highest quality fasteners available.



Now that you have experienced “The Deerwood Difference” ...

Take a few minutes to review what our other companies have to offer.

Please contact your Deerwood customer service representative to learn more about these additional products available to you.



Sure Drive USA® is a leading supplier of construction fasteners. They specialize in deck screws, composite deck screws, stainless steel deck screws, drywall screws and hidden deck fasteners. They offer private label packaging for many of their products. Call 866-767-1850 for information.

www.suredrive.com



Co-Op Screw® distributes a wide variety of fasteners designed and manufactured for the window and door industry. The majority of their products are made from 18-8 and 410 grade stainless steel. They have the ability to develop made-to-order specials to solve your toughest fastener applications. Call 800-445-0477 for more information.

www.coopscrew.com



Atlas Bolt and Screw is the industry leader in manufacturing fasteners for metal to wood and metal to metal applications. Post frame screws with EPDM washers are stocked in over 100 colors to match most metal building applications. They also carry a complete line of closure and other specialty products for the metal building industry. Call them at 800-951-2222 for more information.

www.atlasfasteners.com



Robertson, Inc. is Canada's leading supplier of fasteners to the woodworking and construction industry. Their founder P.L. Robertson invented the Robertson® (square drive) recess in 1908. Robertson, Inc. also provides a complete driver bit and hand driver product line that is custom matched with their recess for optimum performance. Contact them at 800-268-5090.

www.robertsonscREW.com



Western Builders Supply– Big Timber™ construction fasteners are sold exclusively to lumber yards, home centers and farm and ranch stores throughout the US. Our complete line of star drive general construction and structural lag screws is known throughout the industry for their high quality fasteners and competitive pricing structures. Headquartered in Billings, MT. Contact them at 1-800-726-4803 for more information

www.bigtimberfasteners.com

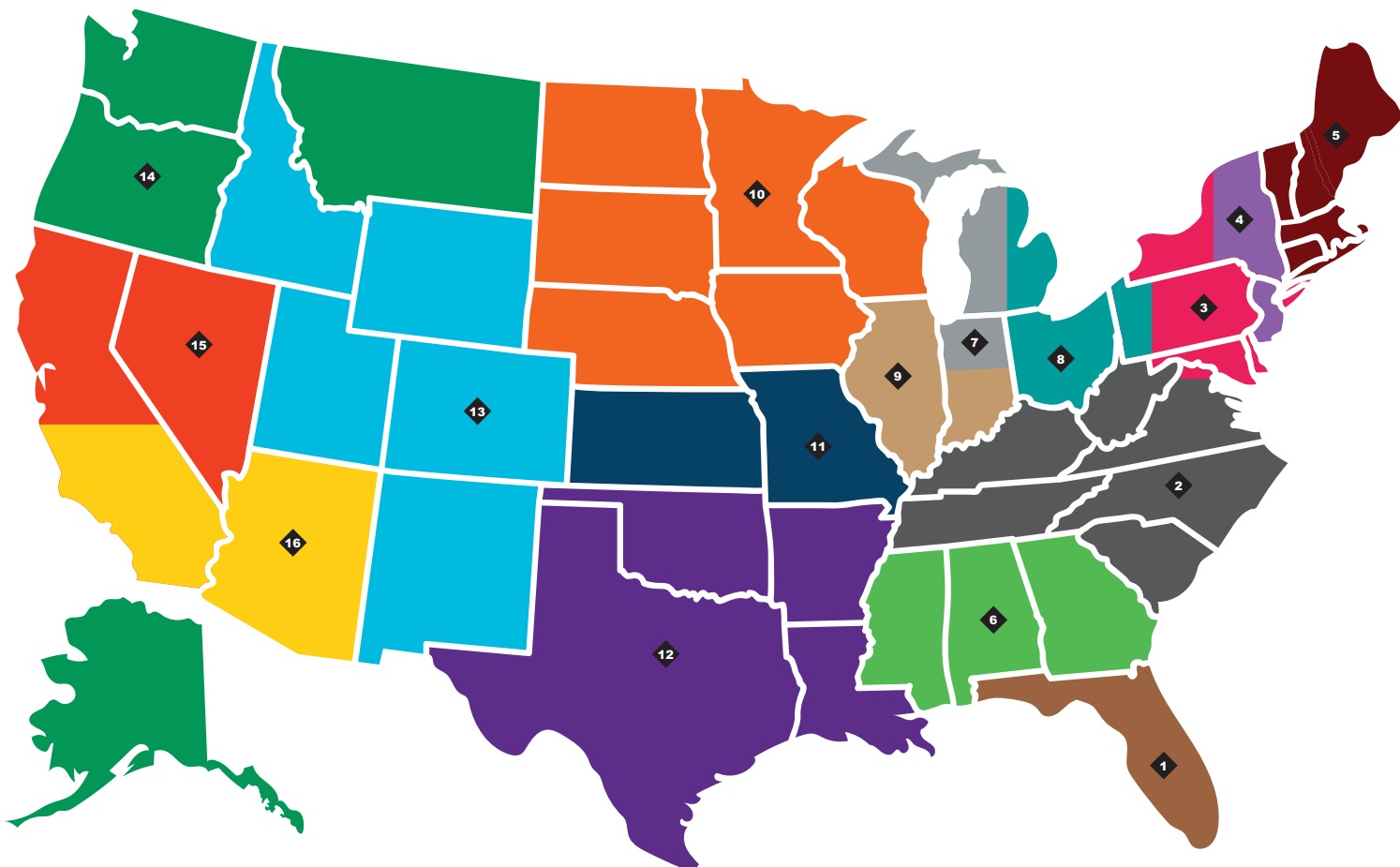

2021 DEERWOOD SALES TEAMS

1. MarJon & Associates, Inc.
7497 N.W. 114th Terrace
Parkland, FL 33076
Tel: 954-575-2112
Email: marjonjohn@aol.com
States: Florida

2. Bair Marketing, Inc.
P.O. Box 1923
Lenoir, NC 28645
Tel: 828-758-9647
Email: sales@bairmarketing.com
Website: www.bairmarketing.com
States: North Carolina, South Carolina,
West Virginia, Virginia, Tennessee,
Kentucky

3. M&M Sales & Marketing, Inc.
1008 Sharon Lane
Westminster, MD 21157
Tel: 484-357-9787; 484-357-9788
Email: mmsalesouth@gmail.com
States: Maryland, District of Columbia,
Delaware, Northern VA, Western NY, 3/4
Pennsylvania (East Side)

4. MKB Sales
20 Old Turnpike Road Lower Level
Suite C-4
Nanuet, NY 10954
Tel: 845-623-0484
Email: twinsanm@aol.com
States: Eastern NY, (including New York
City), New Jersey

5. Open
States: Vermont, Maine, New Hampshire,
Massachusetts, Connecticut, Rhode
Island

6. SDC Sales & Consulting
2035 Daves Road
Morganton, GA 30560
Tel: 404-444-8039; 678-386-7322
Email: steve.ducker@sdcsalesinc.com
States: Alabama, Georgia, Mississippi

7. Dave McVey
2222 Kessler Blvd East Drive
Indianapolis, IN 46220
Tel: 317-696-7666
Email: davejmcvey@gmail.com
States: Western Michigan, Northern
Indiana

8. Triax Marketing & Sales
Tel: 330-301-2000
Email: david@triaxsales.com
States: Ohio, Western PA, Eastern
Michigan

9. Resolute Sales
N 7630 West Bend Road
Theresa, WI 53091
Tel: 414-378-0537
Email: wriebau@resolutesales.com
Website: www.resolutesales.com
States: Illinois, Southern Indiana

10. The Blackburn Company, Inc.
12975 16th Ave N Ste. #200
Plymouth, MN 55441
Tel: 952-934-0104
Email: info@theblackburnco.com
States: Minnesota, North Dakota, South
Dakota, Wisconsin, Iowa, Nebraska

11. Central Components Group
7123 Hwy 47 South; P.O. Box 572
Union, MO 63084
Tel: 314-640-3464; 573-434-6451
Email: kdunn.ccg@gmail.com
States: Kansas, Missouri

12. Horseshoe Wood, Inc.
4310 Wiley Post Road #104
Addison, TX 75001
Tel: 972-484-5162
Email: info@horseshoewood.com
Website: www.horseshoewood.com
States: Texas, Louisiana, Oklahoma,
Arkansas

13. Brunt Sales, LLP
375 Fafnir Drive
Kimberly, ID 83341
Tel: 208-280-2096; 303-304-7821
Email: gardner.blake@gmail.com
danielle.kolar@gmail.com
Website: www.bruntsales.com
States: Colorado, Utah, Idaho, Wyoming,
New Mexico

14. Brandt Industrial Sales, LLC
9511 W. Floyd Dr.
Cheney, WA 99004
Tel: 425-466-4833
Email: lbrandt@brandtindustrialsales.net
States: Washington, Oregon, Montana,
Alaska

15. J-Swis Sales & Marketing, Inc.
Santa Cruz, CA 95060
Tel: 559-906-9674; 559-260-0331
Email: jeffswishersr@gmail.com
jeffswisherjr@gmail.com
Website: www.jswis-sales.com
States: Northern California (half of state),
Nevada

16. Borg Industrial Sales
24056 Continental Drive
Canyon Lake, CA 92587
Tel: 951-553-1818
Email: borgindustrial@gmail.com
States: Southern California (lower half of
state), Arizona

www.deerwood.com

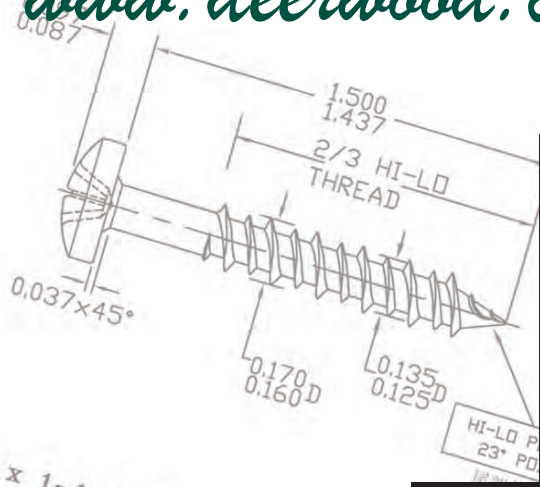
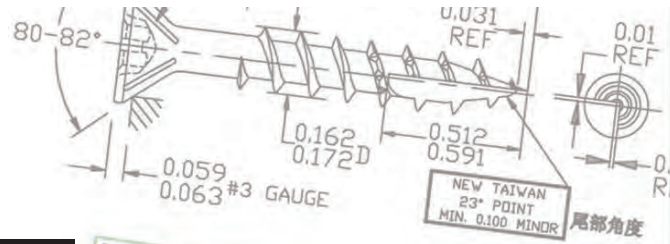

DRAWING NO: 3955008A11052001

3-18 x 1-1/2" #6 PAN HEAD #2 P
STEEL, YELLOW

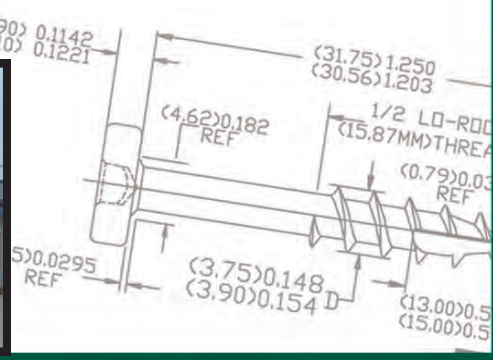

DEERWOOD FASTENERS INTERNATIONAL

OTHERWISE HEAT TREAT SPEC. C-1018 STEEL



7-12x1-1/4 FLAT TOP PAN 2# R
1/2 LO-ROOT, STEEL CASE HA



This is how we have detailed your fastener for manufacturing purposes. Please advise us if this meets your approval.
Approved by _____

638 Reese Drive
Conover, NC 28613
828-469-1075 (local)
828-469-1050 (fax)
800-438-5146 (nationwide)

7-12x1-1/4 FLAT TOP PAN 2# R
1/2 LO-ROOT, STEEL CASE
DATA CONTAINED HEREIN OF ROBERTSON INC. INCLUDING ANY OR IN PART, AND STRICTLY PROHIBITED WRITTEN CONSENT OF
11/01/2020
TOLERANCES UNLESS SPECIFIED OTHERWISE
FRACT. ± 1/64 DEC. ± 0.005 ANGLE ± 0.5°
NTS MATL. SPEC. C-1018 STEEL

8-10 X 1-1/2" #7 PAN PHILLIPS 116 LO-ROOT PHIP
STEEL, CASE HARDENED, YELLOW ZINC PLATING



A Marmon Group / Berkshire Hathaway Company

VED HEREIN ON INC. ANY T, AND IBITED ENT OF

DR. T.R. CUSTOMER DATE: SPEC: